

INSTRUCTION MANUAL  
FOR  
MARINE RADAR  
TYPE RA770UA

ANRITSU CORPORATION

REV. 2.1 FEB. '92

## WARNING HIGH VOLTAGE

High voltage ranging from 300V to 10kV are used in this equipment. Do not touch the inside of the equipment during inspection, repair, or maintenance until you are certain that the power switch on the display unit and main power switchboard are turned off. Even after these switches are turned off, there **may** be high static voltage at condensers, etc. Always ground high-voltage points using an insulated conductor.

### DURING MAINTENANCE OF THE SCANNER UNIT THE ANTENNA MUST NOT BE ROTATED

**Never** start maintenance work on the scanner unit until you are sure that the main power switch on the switchboard and the power switch on the display unit are turned off, and the antenna motor-line in the scanner unit is disconnected **of** from connector 52 on the MOD PC board. Accidental rotation of the antenna is a potential hazard to personnel. A suitable, conspicuous sign such as "**MAINTENANCE IN PROGRESS**" should be posted on the display unit during maintenance **work**.

## CONTENTS

1. **GENERAL**
  - 1.1 Introduction
  - 1.2 Features
2. **OPERATION**
  - 2.1 Key Layout
  - 2.2 Basic Operation
  - 2.3 Sea Clutter Suppression (STC)
    - 2.3.1 Manual Sea Clutter Suppression
    - 2.3.2 Automatic Sea Clutter Suppression
  - 2.4 Rain and Snow Clutter Suppression (FTC)
  - 2.5 Measuring Target Bearings (EBL)
  - 2.6 Measuring Target Ranges
    - 2.6.1 Rough Range Estimation (Range Rings)
    - 2.6.2 To Measure Accurate Ranges (VRM)
  - 2.7 Stretching Echoes from Target for Easy Target Observation
  - 2.8 Plotting locus of Echoes from Moving Targets
  - 2.9 Setting Guard Zone around **Your** Ship
  - 2.10 Off-Centering
  - 2.11 Rejecting Interference from Other Radars
    - 2.11.1 ~~What~~ is Radar Interference?
    - 2.11.2 Rejecting Radar Interference (IR)
  - 2.12 Erasing Heading Marker
  - 2.13 Switching the Display Modes
  - 2.14 The second EBL and VRM
  - 2.15 The floating function of the second EBL and VRM
  - 2.16 Setup Modes
    - 2.16.1 Entering Setup Mode
    - 2.16.2 Return to the Radar Mode
    - 2.16.3 Description of Each Setup Mode
  - 2.17 Navigation Data Display
  - 2.18 Caution
3. **INTERPRETING RADAR PICTURES**
  - 3.1 Propagation Characteristics of Radar Radio Waves
  - 3.2 Echo Strength and Incident Angle of Target
  - 3.3 Shadow Zones
  - 3.4 False Echoes
4. **MAINTENANCE**
  - 4.1 Preventive maintenance
  - 4.2 Checking Fuses and Voltages
5. **INSTALLATION AND ADJUSTMENT**
  - 5.1 Unpacking Instructions
  - 5.2 Installation Materials
  - 5.3 Power Requirements
    - 5.3.1 Power Supply Voltages
    - 5.3.2 Power Systems
  - 5.4 Proper Location for Installation of Radar
    - 5.4.1 Scanner Unit
  - 5.5 Installing Scanner Unit
  - 5.6 Installing Display Unit
    - 5.6.1 Cable Connection
    - 5.6.2 Display unit grounding
    - 5.6.3 Adjustments
  - 5.7 Laying Cables
  - 5.8 Installing the External Buzzer

- 5.9 Interface
  - 5.9.1 Compass Interface
  - 5.9.2 NMEA Interface
- 5.10 Countermeasurement for Electromagnetic Interference(EMI)
  - 5.10.1 On Radar Installation
  - 5.10.2 Radio Equipment and Using Frequency
  - 5.10.3 Improvement Procedure for EMI
- 6. SPECIFICATIONS
  - 6.1 Principal Specification
    - 6.1.1 Overall Characteristics
    - 6.1.2 Scanner Unit
    - 6.1.3 Display Unit
    - 6.1.4 Interface Signals
    - 6.1.5 Allowable Safe Distance from Magnetic Compass
  - 6.2 Standard Equipment

ATTACHED DRAWINGS

General System Diagram	24W137212
Scanner Unit External View	23W61202
Display Unit External View	23W61200
Outline Drawing Rectifier Unit	23W56729
Rectifier Unit External View	
Inter Connection Diagram	24W137213
Scanner Unit Circuit Diagram	24W137121
Display Unit Circuit Diagram	23W61043
Rectifier Unit Circuit Diagram	24W130456
Rectifier Unit Circuit Diagram	24W138330

## 1. GENERAL

### 1.1 Introduction

The RA770UA Marine Radar is a marine navigational pulse radar with 4kW peak power output for small and medium-sized vessels. The Display Unit uses a 10-inch CRT to display monochrome picture images at four different brightness levels.

It is one of a series of digital marine-radars recently developed by Anritsu Corporation.

### 1.2 Features

Many versatile advanced technologies, such as a microcomputer, an LSI exclusively designed for video signal processing, high-integrated LSIs, have been incorporated in the radar circuitry.

As a result, radar video images can be stored and the intensities of signals reflected from targets can be displayed at four different brightness levels.

In addition, various automatic functions, video image expansion, off-centering, plotting, electronic cursor, and offset are provided.

#### a. High Resolution and Sharp Picture

Picture resolution is excellent at short and medium ranges. This unique outstanding feature has been achieved by using a "clean picture" circuit, that is a high resolution circuit developed by Anritsu.

#### b. Automatic Sea Clutter Suppression and Auto Gain Control (AUTO)

In addition to having conventional sea clutter suppression, this radar has a newly-developed automatic sea clutter suppressor.

And not only a sea clutter suppressor, this new radar has an automatic gain control for easy operation.

#### c. Automatic Tuning

To maintain optimum gain at all times, auto-tuning eliminates the possibility of miss-tuning or function lowering of gain.

#### d. Rain, Snow Clutter Suppression (FTC)

Echoes from rain or snow are suppressed by Anritsu's newly-developed FTC circuit. As a result, the visibility of targets has been greatly improved.

#### e. Off-Centering

Your ship's position in the picture can be off-centered from the screen center. The off-centered position can be set to either position of 60% forward or 60% backward .

This results in the effective use of the display size.

#### f. Electronic Cursors :

Electronic Bearing Lines (EBLs) and Variable Range Markers (VRMs)

(i) This radar can display two EBLs and two VRMs.

The VRM range can be displayed by nautical miles (NM), kilometers (KM) or statute miles (SM).  
 (ii) The center of EBL2 and VRM2 can be relocated from the picture center (own ship point) to any point on the picture. This offset facility for EBL2 and VRM2 results in easy measurement of the bearing and range of any two selected points.

g. Guard Zone

An alarm zone sector can be set by using VRM1 and EBL1. The sector angle varies in about 6 degree increments. An external buzzer can be easily installed in addition to built-in alarm buzzer.

h. Plotting picture

The track of target picture can be displayed on the screen. The tracking time can be selected from : 15 sec., 30 sec., 1 min., 3 min., 6 min., and continuous.

2. OPERATION

2.1 Key Layout

The key and control knob layout is shown below.

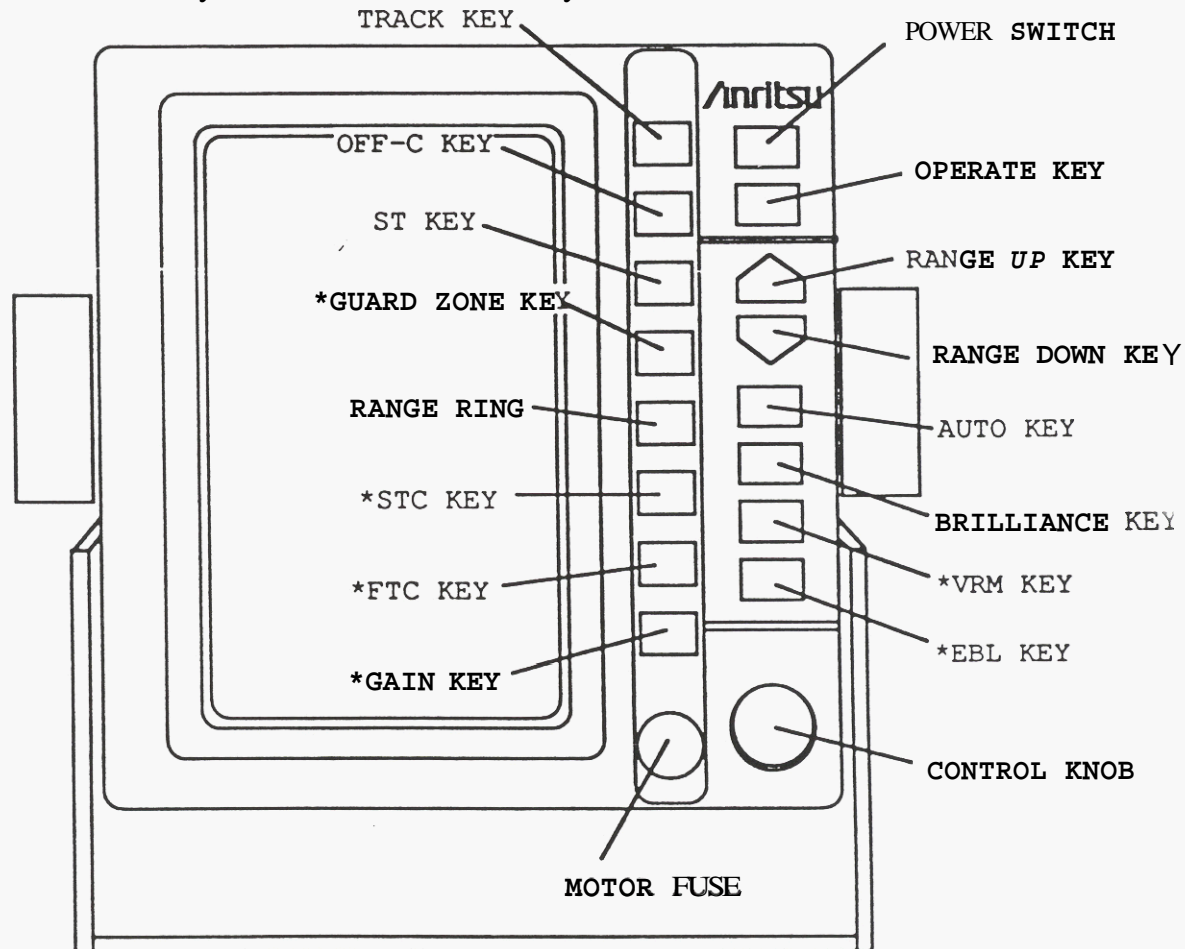

Fig. 2-1

When a key is pressed, normally a short-pitch tone "pi" will be heard. If a long-pitch tone "pi-i-i-" sounds, it indicates that the key input is inhibited.

The keys marked by "\*" in Fig.2-1, are used with the control knob.

## 2.2 Basic Operation

< Starting >

Press the POWER SWITCH. Then, the display shown below will appear on the screen.

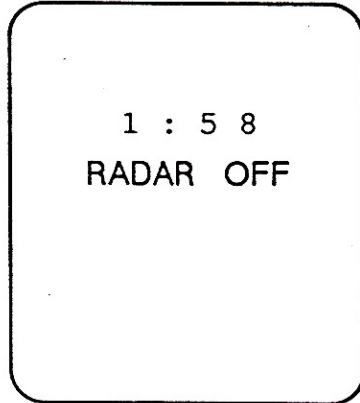

< Lapse of 2 minutes >

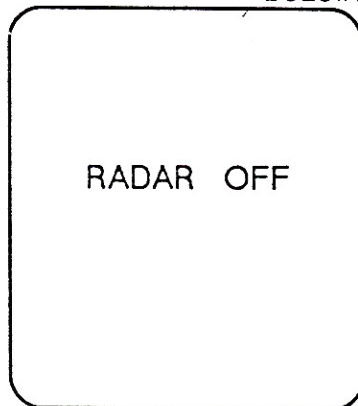

After two minutes, the timer indication disappears and preparation for radar operation is completed. The display is shown below.



< Pulse Transmission  
Start >

Press the OPERATE key.  
The radar will operate and radar picture appears on the screen.

< Range Selection >

Set the required range. Pressing the  key increases the range and pressing the  key decreases the range.



Range (NM)	Pulse Width (μs) / Repetition (Hz)
12, 24, 36	0.8 / 600
6	0.25 / 1200 *(ST ON: 0.8 / 600)
1.5, 3	0.08 / 1800 *(ST ON: 0.25 / 1200).
0.125 to 0.75	0.08 / 1800

\*ST : Stretch Function

< Gain Adjustment >

Press the GAIN key to set the gain adjustment mode. The underline shown below will be displayed on the screen.

S 0 F 0 G 30



Indicates that the gain adjustment mode is selected.

Turn the control knob to adjust the gain. The gain adjustable range is from 0 to 50.

Turning the control knob clockwise elevates the level, enhances reception sensitivity and makes targets visible. Turning the control further clockwise changes the brightness level of echo signals reflected from targets with high reflection coefficients. For long-range observations, increase the gain by turning the control knob clockwise so that slight receiver noise can be observed. (Receiver noise usually appears on the entire surface of the display as speckled noise.)

Conversely, excessive gain at short range will obscure the picture with noise and unwanted echoes. Small targets will be concealed in the obscure areas.

In such a case, turn the control knob counterclockwise to the appropriate point. The intensities of signals reflected from targets are expressed as changes of brightness.

< Picture Brilliance Adjustment >

Press the key to change the CRT brightness and the panel illumination. One press varies the brilliance by one level.





< Operate Keys and Controls Depending on Circumstances >

Refer to paragraph 3.2 and after.

< To suspend radar operation >

Press the OPERATE key once. The radar will stop transmission and the radar picture will disappear. To resume radar operation, press the OPERATE key once more.

< To Stop Radar Operation >

Press the POWER SWITCH more than 3 seconds.

## 2.3 Sea Clutter Suppression (STC)

### 2.3.1 Manual Sea Clutter Suppression

( STC: Sensitivity Time Control)

(i) Press the STC key. The underlined numerical indication shown below will be displayed and the sea clutter suppression mode (STC) will be set.

S 0 F 0 G 3 0  
↑

Indicates STC adjustment mode is selected.

(ii) Turn the control knob to adjust the level. The STC adjustable range is from 0 to 50.

Sea clutter is observed from short-range sea surfaces even when the sea is calm. When the sea is rough, intense echoes appear over a wide area and sometimes make targets invisible.

The STC control decreases such sea clutter and makes targets easily visible. Turn the control knob clockwise to decrease sea clutter. If the control knob is turned too far, echo signal from important targets may disappear. Adjust the control very cautiously by observing the picture with utmost care.

Usually the STC control should be set so that there is no sea clutter at or near the display center when the sea is calm, with the distance range preset to a minimum or 0.125 NM.

The STC circuit is designed primarily to make the short-distance sensitivity (gain) lower and the long-distance sensitivity (gain) higher. For this reason, no picture may emerge on the display if the sea is calm and there are no large targets near your ship when the range is set to 0.125 to 0.5NM and the level is more than 30.

### 2.3.2 Automatic Sea Clutter Suppression

(1) Automatic Sea Clutter Suppression and Automatic Gain Control

Press the AUTO key. The indication shown below will be displayed and the auto sea-clutter suppression mode

Press the AUTO key. The indication shown below will be displayed and the auto sea-clutter suppression mode will be set. At the same time, the auto gain control mode will be set.

Press the AUTO key again. The indication will change to "AT 2" and the auto sea-clutter suppression will enhance the effect.

AT 1



Indicates the auto STC and auto gain mode is selected.

(2) Automatic Sea Clutter Suppression and Manual Gain Control

Press the GAIN key to return to manual gain control mode. The indication shown below will be displayed and the auto sea-clutter suppression mode will remain.

AT 1

G 30



Indicates the auto STC and manual gain control mode is selected.

(3) Automatic Sea Clutter Suppression, Manual Gain Control and FIC Control

Press the FIC key to add the FTC control mode. The indication shown below will be displayed and the auto sea-clutter suppression mode will remain.

AT 1 F 0 G 30



Indicates the auto STC, manual gain and FIC control mode is selected.

(4) Manual control

Press the STC key to return to the manual control mode. The indication shown below will be displayed.

S 0 F 0 G 30



Indicates the STC adjustment mode is selected.

## 2.4 Rain and Snow/Clutter Suppression (FTC)

(i) Press the FIC key. The indication shown below will be displayed and the rain and snowclutter suppression mode (FTC) will be set.

S 0 F 0 G 30

Indicates the FTC mode is selected.

(ii) Turn the control knob to adjust the level range from 0 to 50.

Clutter from rain, snow or fog may appear on a radar picture and sometimes mask targets completely invisible.

In such a case, turn the control knob at the FIC mode clockwise. Then the contours of concealed targets will appear. Since the radar uses a LOG amplifier, the FIC function is very effective. But it tends to weaken the intensities of echoes from short-range targets. Adjust STC and gain for the best picture.

Always turn the control knob at the FTC mode fully counterclockwise to level 0 when there is no rain or snow. In this state the FIC function is ineffective.

## 2.5 Measuring Target Bearings (EBL)

Press the EBL key to select the electronic cursor and the indication below will be displayed on the bottom of the screen. Turn the control knob to move the EBL to coincide with the target to measure the bearing from your ship's heading. Press the EBL key once again to erase the EBL. (To erase the EBL, the EBL function must be selected at the moment.)

EBL 0.0'

## 2.6 Measuring Target Ranges

### 2.6.1 Rough Range Estimation (Range Rings)

Press the range ring key. Fixed range marker rings will be displayed as shown below. The interval of range marker rings depends on the range as tabulated below:

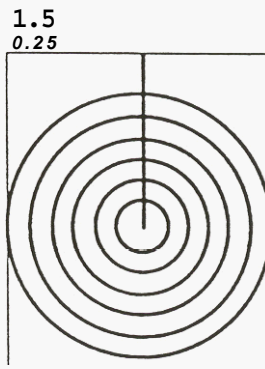

Press the range ring key once more to erase the range marker rings.

Range (NM)	0.125	0.25	0.5	0.75	1.5	3	6	12	24	36
Ring Interval (NM)	0.0625	0.125	0.25	0.25	0.25	0.5	1	2	4	6
Number of Rings	2	2	2	3	6	6	6	6	6	6

### 2.6.2 To Measure Accurate Ranges (VRM)

Press the VRM key to select the variable range marker ring and the indication below will be displayed on the bottom of the screen. Turn the control knob to move the VRM to coincide with the target to measure the accurate range from your ship. Press the VRM key once again to erase the VRM. (To erase the VRM, the VRM function must be selected at the moment.)

VRM 0.0NM

### 2.7 Stretching Echoes from Target for Easy Target Observation

Press the ST key. The stretching function is set and the indication "ST" is displayed on the upper-right position of the screen.

This stretching function is mainly used when echoes from medium or longrange targets are too small for observation. Press the ST key once more to release the function.

### 2.8 Plotting Echo Track from Moving Targets

Press the TRACK key to plot echoes (picture) and the indication below will be displayed on the top-right of the screen.

TRACK 15SEC

The track of target picture is displayed on the screen. The tracking time can be selected from : 15 sec., 30 sec., 1 min., 3 min., 6 min., and continuous.

To erase the track of target picture, press the TRACK key more than 3 seconds.

### 2.9 Setting Guard Zone around Your Ship

The guard zone function is used to warn against possible collision with other ships, for surveillance, and warn against running ashore.

(i) Press the VRM key and turn the control knob to set the range of guard zone.

(ii) Press the EBL key and turn the control knob to set the EBL direction of the guard zone.

(iii) Press the GZ key. The guard zone is set and displayed as an area bounded by solid lines. The angle of the guard zone is set in 5.625 degree increments. To change the guard zone area, press the GZ key. The area will change as 45, 90, 180, and 360 degree, and move to the current VRM and EBL position.

If a target trespasses into the guard zone, an audible alarm sounds (pi-pi). The alarm sounds until the GZ key is pressed. If a new target trespasses into the guard zone, the alarm sounds again.

To erase the guard zone, press the GZ key more than 3 seconds.

- Notes: 1 The guard zone is maintained even if the range key is used to change the distance.  
2 If the powerful alarm is required, install an external buzzer (see 5.8).

#### 2.10 Off-Centering

This function is used when the picture in an end of the screen must be observed more clearly or widely.

Press the OFF-C key. The picture center will move to the 60% backward of the screen. Press the OFF-C key once more. It will move to the 60% forward of the screen. And then, another press moves the picture center to the center of the screen.

#### 2.11 Rejecting Interference from Other Radars

This function is not set to a key as standard. To use this function, refer to "2.14 Setup Modes, Selectable Key".

##### 2.11.1 What is Radar Interference?

Radar interference may occur when another radar on the same frequency band is operating near your ship. The form of the interference pattern is not constant; it may be broken-line arc or a broken line. Since interference echoes vary with every scan period, it is easy to distinguish interference patterns from normal echoes.

##### 2.11.2 Rejecting Radar Interference (IR)

The interference reject function is equipped as standard.

#### 2.12 Erasing Beading Marker

This function is not set to a key as standard. To use this function, refer to "2.14 Setup Modes, Selectable Key".

When a target is masked by the heading marker line, use this function to erase the heading marker.

#### 2.13 Selecting Display Mode

This function is not set to a key as standard. To use this function, refer to "2.14 Setup Modes, Selectable Key".

When Gyro compass is connected to the radar, the display mode can be changed to;

- (i) **Head Up** The ship's heading direction is displayed on the 0 degree of the screen.
- (ii) **Course Up** The ship's course direction is displayed on the 12 o'clock of the screen. Once entering this mode, the picture direction is set to the direction that the ship's heading is directed.
- (iii) **North Up** In this mode, all the targets are displayed so that true north (bearing = 0 degree) comes at 0 degree of the screen at all times in connection with a gyro. Therefore, the picture looks like a chart and fixed targets remain stationary despite the yawing of your ship.

When **no** Gyro compass is connected to the radar, the display mode can be changed to;

- (i) **Head Up** The ship's heading direction is displayed on the 0 degree of the screen.
- (ii) **Head Set** The ship's heading direction is displayed on the EBL direction of the screen.

#### 2.14 The second **EBL** and **VRM**

The second EBL and VRM are available when the selectable-function keys are set to these functions at SETUP menu. The numerical data of these functions are displayed on the same position as navigation data. In this case, navigation data such as **Latitude/Longitude** and/or **XTE(Cross Track Error)** is not displayed on the radar screen.

#### 2.15 The floating 'function of the second **EBL** and **VRM**

The floating function of the second EBL and VRM is usable when this function is set to a key by SETUP menu. When the first EBL and VRM are displayed, the origin of the second EBL and VRM can be moved to the cross point of the first BEL and VRM by using the floating key. Only the underlined function(the second EBL **or** VRM) is movable. This origin is fixed onto the screen, and not followed the off-center **or** the range up/down control.

#### 2.16 Setup Modes

The setup modes are not used to operate the radar in themselves; they are primary intended to check each function and setup the initial condition.

##### 2.16.1 Entering Setup Mode

**Press** the brilliance control key more than 3 seconds. Then MENU is displayed **as** below.

##### MENU

- (1) SYSTEM CHECK
- (2) DISPLAY PRESET
- (3) KEY ASSIGNMENT
- (4) AUTO TUNE CALIBRATION
- (5) TIMING ADJUSTMENT
- (6) HEAD DIRECTION ADJUSTMENT

Press the range up/down key as many times as required to underline any desired setup mode number.

Then, press the brightness control key. The selected setup mode **is** set.

### 2.16.2 Return to the Radar Mode

Press the operate key. The radar picture emerges.

### 2.16.3 Description of Each Setup Mode

#### (1) SYSTEM CHECK

This **mode** is for checking whether voltage and signals at various sections are appropriate. If they are normal, "OK" is displayed as shown below. Otherwise, "NG" is displayed.

#### MEMORY CHECK

ROM	019111	OK
RAM		OK
NVRAM		OK

#### SIGNAL CHECK

(1) TRIGGER	OK	
(2) SHF	OK	
(3) AZIMUTH	OK	
(4) VIDEO	OK	
(5) +5v	OK	5.0V
(6) +12V	OK	12.0V
(7) H.T.	OK	300 V

#### (2) DISPLAY PRESET

This mode initializes the settings of the various functions. Select a desired item with the range up/down keys and adjust with the control knob. See Figure below.

#### DISPLAY PRESET

A. VRM UNIT	<u>NM</u>	KM	SM
B. BUZZER VOLUME	<u>HIGH</u>	LOW	OFF
C. PICTURE HOLD	<u>OFF</u>	ON	
D. SHF FLASH	<u>OFF</u>	<u>ON</u>	
E. PARALLEL CURSOR	<u>OFF</u>	ON	
F. NORTH MARK	<u>OFF</u>	ON	
G. STC CURVE (NORM 3)			3

#### (3) KEY ASSIGNMENT

The panel keys on the left-hand can be changed **for** the users to select desired functions. Eight functions among the functions below can be preset.

TRACK, OFF-C, ST, GZ, **RINGS**, GAIN, STC, FTC, HM(SHF OFF), MODE, EBL2, VRM2, FLT(floating for EBL2 and VRM2), IR(Interference Rejection)

1	1 TRACK
2	2 OFF-C
3	3 ST
4	4 GZ
5	5 RINGS
6	6 STC
7	7 FTC
8	8 GAIN
	9 HM
	10 MODE
	11 EBL2
	12 VRM2
	13 FLT
	14 IR

Select the key position by the range up/down key, and set the function number to the key by the control knob. Replace the KEY-CAP with the new function's one.

(4) AUTO TUNE CALIBRATION

Before enter the Setup mode, set the range scale to 12 NM.

This mode is used to adjust the auto-tuning system for the maximum visibility of the target echoes.

(i) Set the mode to "2 CALIBRATION" by the range up/down key, and turn the control knob to get maximum picture visibility. In this condition, the tuning system is in manual mode.

(ii) Then set the mode to "1 AUTO", and auto tune system calibration will be carried out. The calibration will take several minutes.

(iii) When the calibration is finished, the "CALIBRATION COMPLETED" is displayed on the screen. The auto-tuning calibration voltage is displayed at "CONTROL" area.

(5) TIMING ADJUSTMENT

This mode is used to adjust the timing for distance to target.

Set the detection range to 0.125 or 0.25 NM, operate the radar, and enter this setup mode to adjust the timing. Then turn the control knob to decrease the diameter of the inner ring of the bright sunspot until the diameter becomes nil and coincides with the sunspot center.

(6) HEAD DIRECTION ADJUSTMENT

This mode eliminates the angular difference between the heading direction of the scanner installed on the ship and that of the displayed picture. When the control knob is turned clockwise, the heading marker on the picture moves counterclockwise (the picture on the screen turns counterclockwise); turning the control knob counterclockwise makes the heading marker move clockwise (the picture on the screen turns clockwise). Each movement is in 0.1 degree steps.



## 2.17 Navigation Data Display

### (1) Latitude/Longitude

When the Latitude/Longitude data from a navigational equipment are fed through the NMEA-0183(format:GLL), the Latitude/Longitude data are displayed automatically on the **lower** part of the screen.

### (2) Cross Track Error

When the Cross Track Error data from a navigational equipment are fed through the NMEA-0183(format:XTE), the Cross Track Error data are displayed automatically on the lower part of the screen. The number of triangle marks depends on the error value.

X T E (NM)	INDICATION
0.00-0.01	
0.02-0.03	
0.04-0.07	
0.08-0.15	
0.16-	

marks shows steering direction.

### (3) Speed/Course

When the Ship's Speed/Course data from a navigational equipment are fed through the NMEA-0183(format:VTG), the Ship's Speed/Course data are displayed automatically *on* the upper part of the screen. When a fluxgate-compass or a gyro-compass is connected to the radar, the compass heading is displayed instead of the "course" data of navigational equipment.

### (4) Compass Heading

When the Ship's Heading data from a fluxgate compass are fed through the NMEA-0183(format:HDM), the Ship's Heading data are displayed automatically on the upper part of the screen.

### (5) Latitude/Longitude of any point on the screen

When the Latitude/Longitude and Ship's heading(or course) are displayed on the screen, the Latitude/Longitude of any point on the screen can be displayed.

(5)-1 When the EBL and the VRM are used at the same time, the indication LAT/LON will change to reverse character. During this indication, the Latitude/Longitude data show that at the cross point of the EBL and the VRM.

(5)-2 To stop this indication, erase the EBL or VRM. Then the LAT/LON character will return to normal, and the data will return to your ship's position.

(6) Waypoint

Ship's heading or course information from a compass and waypoint data from a navigational equipment are necessary to display a waypoint. When the NMEA-0183(format: BWR, BWC, BER, BEC, BPI) is fed from the navigational equipment, waypoint marks are displayed with a dotted line and a circle. When a loran is used as the navigational equipment, the dotted line is not displayed on the screen.

**2.18 Caution**

**POWER FAIL**

If "RADAR OFF POWER FAIL" is displayed on the screen(see figure below.), it indicates that the power supply voltage has dropped a moment. Check the radar power lines or batteries.

RADAR OFF  
POWER FAIL

### 3. INTERPRETING RADAR PICTURES

Echoes appearing on the radar screen vary greatly according to target configuration, weather conditions, and operating methods. You must train yourself to understand the characteristics of radar, acquire the proper methods for handling the controls and correctly interpret the information obtained from the display.

#### 3.1 Propagation Characteristics of Radar Radio Waves

Radar radio waves can be bent slightly during propagation along the curvature of the earth. The amount of bending depends on the density of the air in the atmosphere, etc. Under normal propagation, the radar's horizon distance (D) is greater than the optical horizon distance by about 6% and is shown as:

$$D \text{ (NM)} = 2.22 (\sqrt{h_1} + \sqrt{h_2})$$

Where  $h_1$  = antenna height in meters

$h_2$  = target height in meters

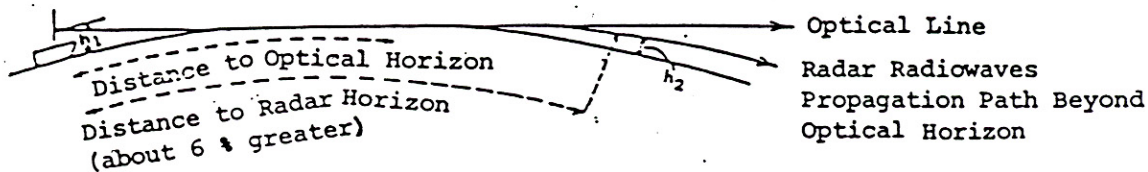
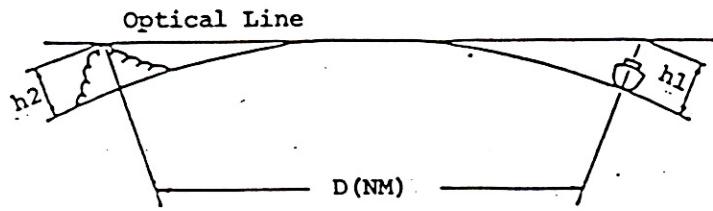

Fig. 3-1 Propagation Path of Radar Radio Waves

Figure 3-2 is used to find the distance of a target detected by a shipborne radar, assuming that the antenna height is 3 m, 15 m, and 30 m and that the target height ( $h_2$ ) varies from 0 to 3000 m.

Radiowave  
propagation  
path



$$D = 2.22(\sqrt{h_1} + \sqrt{h_2})$$

D: (NM)  
h1, h2: (m)

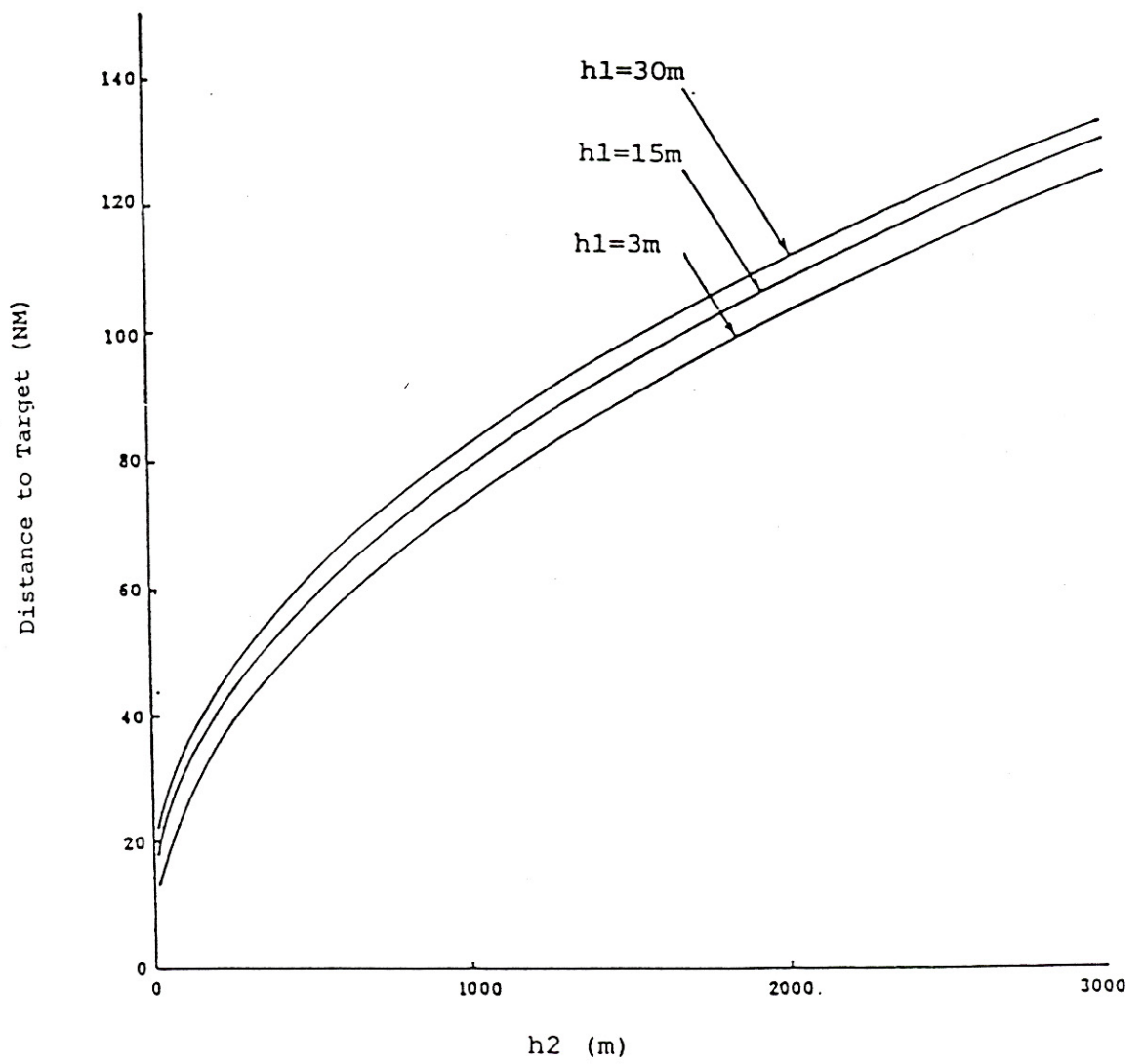

Fig. 3-2 Height of the Target Above Sea Level

### 3.2 Echo Strength and Incident Angle of Target

The strength of an echo pulse, arriving at the radar receiver from a target, is dependent not only upon the distance to the target, its height above sea level and size, but also upon the target configuration and material.

Accordingly, an echo signal reflected from a high, large target is not always strong; a strong echo may return from a low target, if its surface is comparatively vertical (and smooth) with respect to the transmitted radiowaves.

As the angle of incidence of radiowaves, with respect to the surface of a target, decreases beyond a certain angle, the intensity of the echo signal decreases greatly. Intensities of echo signals reflected from gradually sloped surfaces such as sandy beaches or cone-shaped lighthouses are very faint. Echoes from locations considerably removed from a coastline may, at times, be displayed on the screen as if they are a coastline (Fig. 3-3). You must train yourself not to mistake such echoes for coastline.

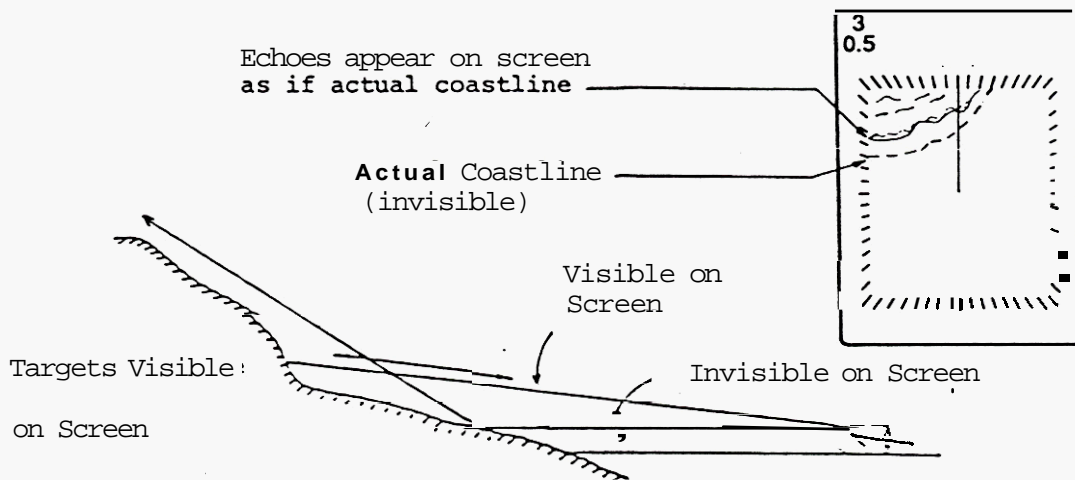

Fig. 3-3. Echo Strength and Incident Angle of Target

### 3.3 Shadow Zones

Radar radiowaves travel in a straight line in much the same manner as light. A local, partial or total shadow zone may be produced by a funnel, mast, or a derrick post near the antenna or a high target or mountain at a short distance. In extreme cases, shadows may be produced at long ranges and no target echoes are displayed on the screen in their presence.

Local shadow zones, produced by funnels, masts, etc. can easily be discovered when the antenna is installed. These zones can be reduced by changing the location of the antenna installation.

### 3.4 False Echoes

Echoes from targets which do not actually exist in that direction may appear on the CRT. They are referred to as "false" or "indirect" echoes. The causes and phenomena of such false echoes are listed below.

#### Virtual or Ghost Echoes

A large target at close range may, at times, appear on the screen as two echoes in two separate directions. One is a real echo and the other is a virtual, or ghost, echo caused by secondary reflection of emitted pulses by funnels, masts, etc. The former appears at the correct range and bearing, while the ghost appears at a range and bearing behind the funnel or the mast (Fig. 3-4).

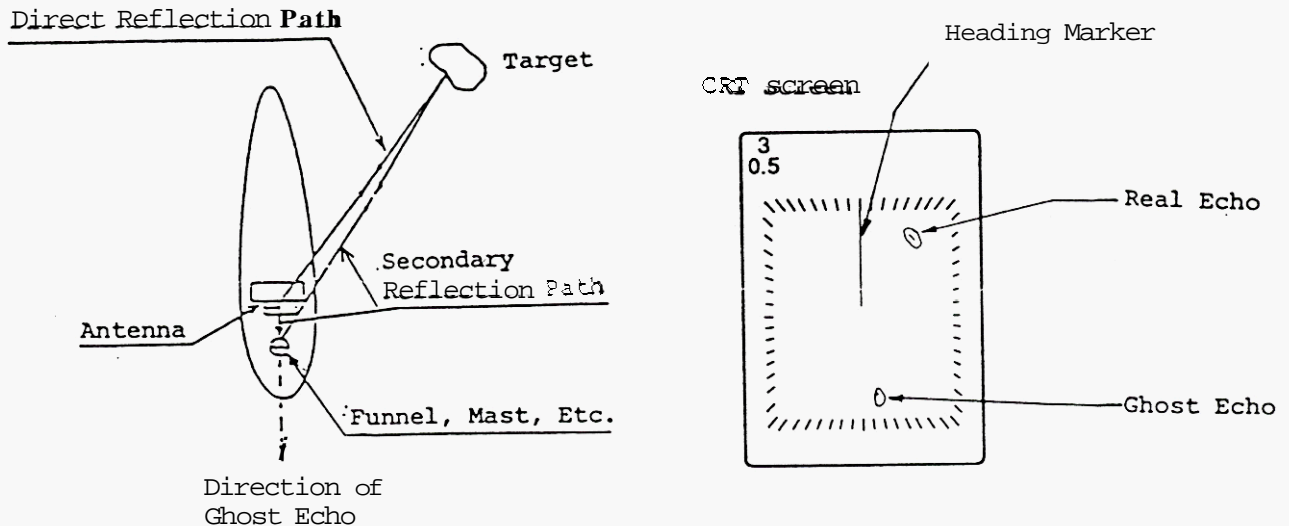

Fig. 3-4 Virtual or Ghost Echoes

When a target is on the funnel or mast side, a series of ghost echoes may appear in the vicinity of a real echo. The principle of this phenomenon is the same as mentioned previously. When the intensities of reflected waves change, a number of ghosts can be detected (Fig. 3-5). But, they are arranged asymmetrically with respect to a real echo and vanish when the ship's heading changes.

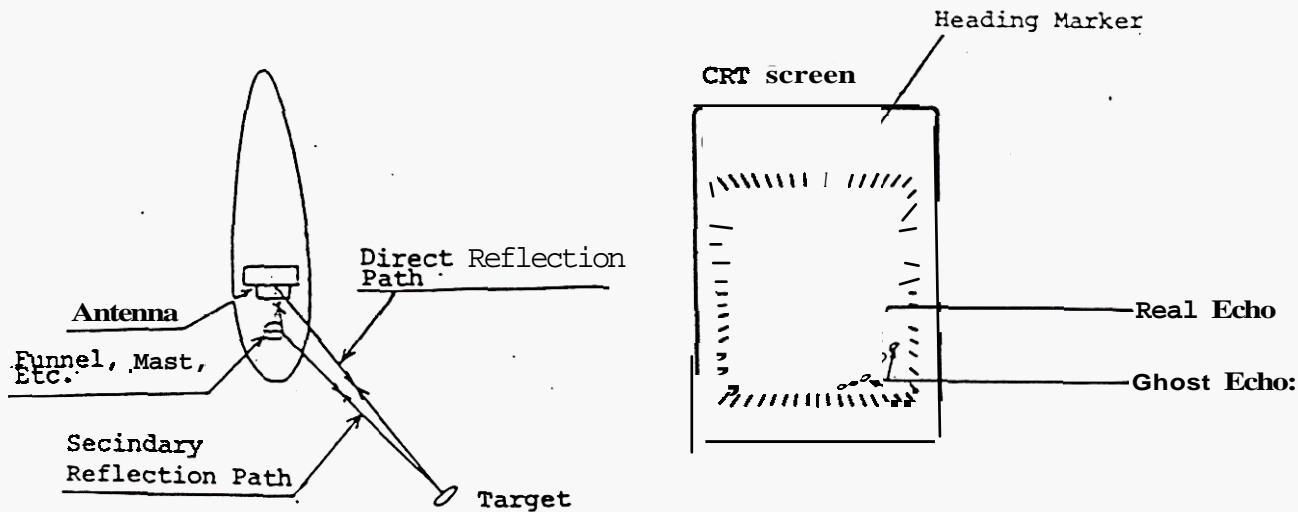

Fig. 3-5 Virtual or Ghost Echoes

### Multiple Echoes

When there are vertical reflective surfaces at short range, for instance, when your ship passes a larger ship, the pulsed waves emitted from your radar will bounce back and forth between the two ships (Fig. 3-6). As a result, a few equi-distant echoes may appear in the same bearing on the screen. These echoes are called multiple echoes. They disappear as your ship moves away or changes bearing from the reflecting target.

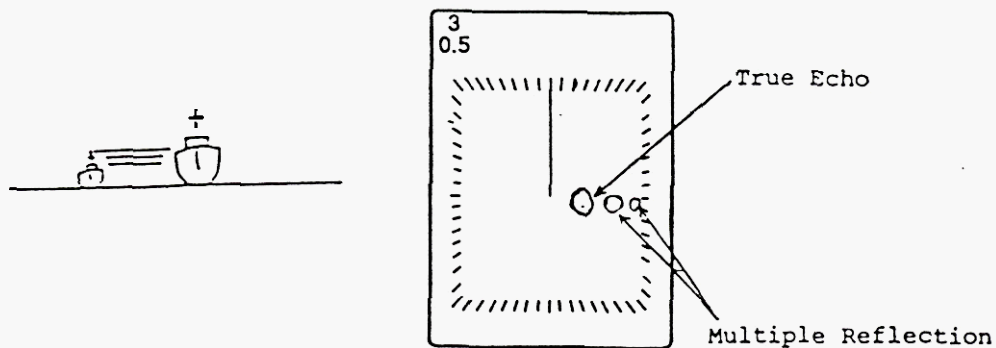

Fig. 3-6 Multiple Echoes

### Side-lobe Echoes

The beam radiated from a radar antenna is composed of a main beam and side-lobe beams. Since the energy levels of side lobes are usually low, false echoes from the side lobes can be produced by highly reflective targets at short range (Fig. 3-7). Side lobe echoes usually appear as a series of echoes forming a broken arc. These false echoes are eliminated by slightly increasing the STC effect.

(Note: This echo is similar to virtual or ghost echoes.)

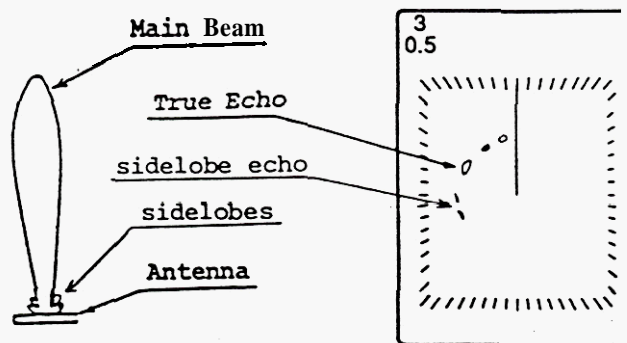

Fig. 3-7 Arc of False Echoes caused by Side Lobe Beams

### Echoes Produced by Targets at Long Ranges Due to the Duct Phenomenon

Depending on the atmospheric conditions, a radio-wave duct may form above the sea surface. In such cases, radiowaves can be trapped in the duct, travelling in an unusual way over unexpectedly long distances. Targets beyond maximum detectable range may appear as echoes on the screen as if they are nearer than their true ranges. This phenomenon is attributable to the fact that an echo signal from a long distance target is delayed beyond the repetition period so as to be displayed as an echo in the succeeding period. However, if the range is changed by pressing the RANGE key, the echo can be immediately judged false.



#### 4. MAINTENANCE

##### 4.1 Preventive maintenance

Extensive use of integrated circuitry and solid-state technology throughout the equipment ensure a high degree of reliability over a long, trouble-free service life. There is little possibility that problem will occur within a few years of installation, provided preventive maintenance is properly carried out.

Preventive maintenance for the RA770UA radar must be performed regularly to ensure satisfactory operation and performance, reduce the possibility of electrical and mechanical malfunctions, and to prolong service life.

The maintenance to be performed at regular intervals are listed on the following pages.

**WARNING:** *Never* inspect the equipment when the **POWER SWITCH** on the display unit is turned *ON* (The power switch on the switchboard must be turned *OFF*. For more safty maintenance, take of fuses on the display unit.). After the **POWER SWITCH** is turned *OFF*, high static voltage may be retained in the CRT high-voltage circuit and capacitors are a potential hazard to personnel. Discharge high static voltages to ground by using an insulated conductor before maintenance.

Location	Maintenance Period	Procedure
Antenna radiation surface (radome surface)	Once every 3 to 6 months	Check radiation surface(radome) for clogging or accumulation of soot, salt, oil, or paint. If found, rinse the surface with pure water and wipe off moisture with a soft, clean cloth. (Never use solvents such as gasoline, benzine, trichloroethylene, or "thinner".
Scanner Unit mounting		Check for loose bolt-nuts and corroded portions of scanner unit mount and baseplate.
Inside of Scanner Unit		Check for loose contact on each connector of printed circuit board, and for imperfect mounting of any component. If loose, re-tighten with a wrench. Also check for improper seating of the gasket for the cover, corroded portions in the interior surfaces or on case surface.
Display surface		Clean the display surface with a soft, pure water moistened cloth.

Location	Maintenance Period	Procedure
Antenna driving pinion-gear mechanism	Once every 6 to 12 months	Apply selected quality grease on all surfaces of antenna driving gear using a suitable spatula.
Cleaning CRT HV parts		Clean the anode cap of the CRT, its vicinity, and HV leads with a dry cloth. Note that HV of about 10 kV is applied to the CRT. NEVER inspect until you are SURE the radar power source is turned OFF. High static voltage may be retained in the CRT high-voltage circuit and the CRT. Discharge high static voltages to ground by using an insulated conductor before maintenance.
Cleaning printed circuit boards		If soot, dirt, and dust accumulate on densely-mounted components, unexpected trouble may result. Clean using a vacuum cleaner with a soft brush.
Connectors		Check all connectors for poor contact. If present, repair or replace it.
Screw within display unit		Check all fabrication or mounting screws inside display unit for looseness. If loose, re-tighten with a screwdriver.

#### 4.2 Checking Fuses and Voltages

Check fuses and voltages on the power supply unit when any CHECK item in SETUP mode shows the radar is faulty, or check function itself does not work. Fuses blown up show that some causes of malfunction have existed in the radar such as shorting circuits. Table below lists fuses and voltages.

Location and Fuse	Rating Current	Rating Voltage	Using Voltage	Common Terminal	Voltage range	Current
Display unit-F1 (main fuse)	5A/12V 10A/ 24, 32V	250V	Input	POWER PCB/J1-4	(24V) ship's power supply	(2.5A)

Display unit-F2 (Motor Fuse)	0.3A	250V	12V	Chassis	11.5 to 12.5V	0.03A
POWER PCB-F1	2A	250V	5V	Chassis	5.0V to 5.3V	0.9A
MONITOR PCB F901	2A	250V	12V	Chassis	12.0V to 12.2V	1.5A

## 5. INSTALLATION AND ADJUSTMENT

### 5.1 Unpacking Instructions

- (1) When unpacking the display unit packing, take care not to excessive force or damage the panel.
- (2) Visually check for any damage caused during transportation.
- (3) Count and check for all accessories to avoid confusion and loss.
- (4) If any part of the equipment or its associated components have been damaged during transportation, report the damage IMMEDIATELY in detail to the transportation agency.

### 5.2 Installation Materials

All necessary materials for installing are listed in Table 5-1. Materials other than accessories should be procured on-site by the installer.

Table 5-1 Installation Materials

Name	Qty.	Use	Remarks
Inter-connection Cable(9CD-3349)	1 pc.	To connect scanner and display units	Accessory(10m)
Power Supply Cable	1 pc.	To connected to power source	Accessory(2m)
Cable Clamp Material	2 pcs. each 1m long	To clamp inter-connection cable	
Bolt	4 sets	To mount scanner unit	Accessory
Bolt-nut	5 sets	To mount display unit	
Crimp Style Terminal	1 pc.	To ground display unit	
Grounding Cable	1 pc.	To ground display unit	
Main Switchboard	1	For power supply	
Insulation Tape	1 roll		
Collar		Used for cable passing through wooden wall board	
Steel Conduit or Pipe		Used for cable passing through steel wall plates	

### 5.3 Power Requirements

A reliable, and noise-free power source with minimum voltage fluctuation is needed to operate the radar satisfactory. Care should be exercised regarding the below listed items.

#### 5.3.1 Power Supply Voltages

The RA770UA can operate on any of the power supply voltage listed in Table 5-2. For dc power supply, the dc voltage is directly supplied to the RA770UA. When it works with ac power supply, use the rectifier unit which is an optional equipment.

Table 5-2 Power Supply Voltage

Power Supply Voltage	( ): Fuse	Power Consumption (maximum)	Permissible Voltage range	Description
DC	12 V (10A), 24 V (5A), 32 V (5A)	6.5 A 3.5 A 2.5 A	10.2 to 41.6 V	Input voltage of display unit
AC	100, 110, 220 V 50/60Hz	Less than 120 VA	+/- 10%	Input voltage of Rectifier Unit (optional)

#### 5.3.2 Power Systems

Power is fed through a knife switch (or circuit breaker) and protective fuses, as shown in Fig.5-1 and 5-2.

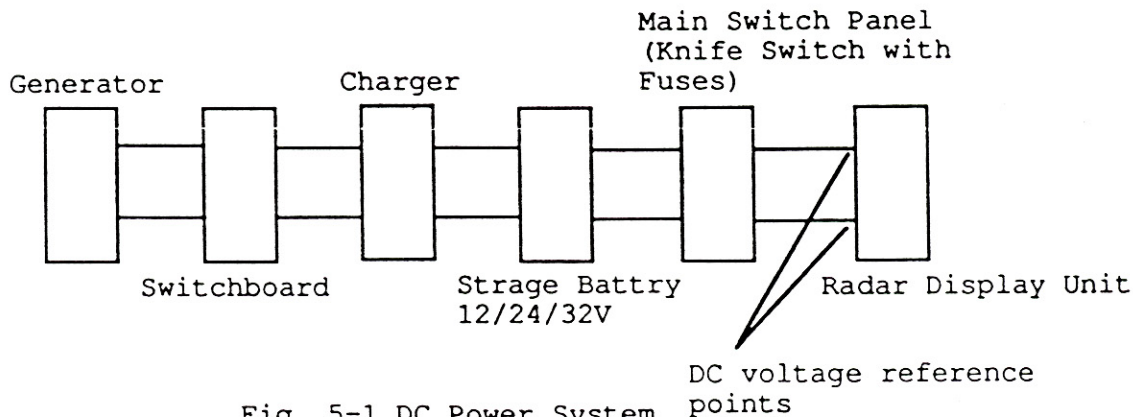

Fig. 5-1 DC Power System

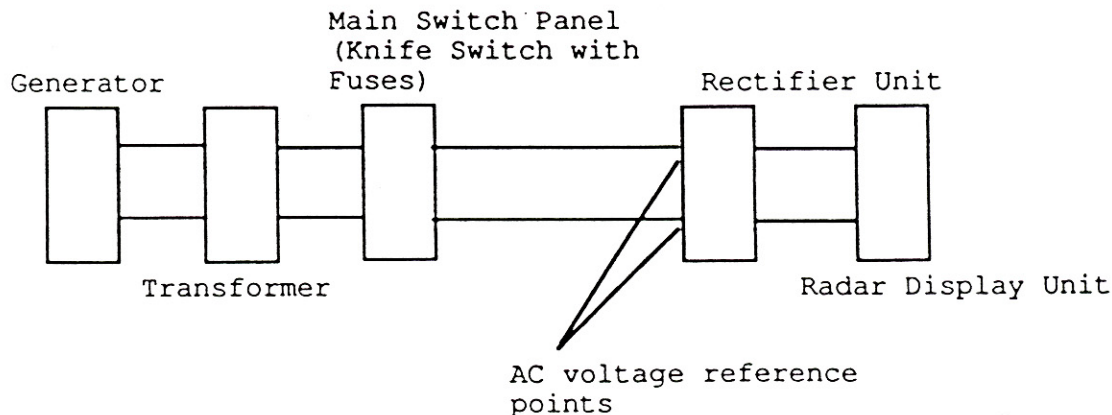

Fig. 5-2 AC Power System

## 5.4 Proper Location for Installation of Radar

### 5.4.1 Scanner unit

The target detection capabilities of shipboard radars are governed by the location of the Scanner unit. An ideal location would be a point as high as possible above the keel line, where there are no obstacles in all azimuthal directions which might interfere with the transmission of radar pulses and reception of returning echoes.

Although all ships are subject to various limitations, sufficient consideration must be given before selecting an optimal point.

1. The "radio ranging" distance-increases with the height of the scanner installation. Install the scanner **as** high as possible, after investigating the structural features of the ship and maintainability of the scanner unit.
2. If a part of the funnel or mast is in the same horizontal plane as the scanner unit, radar pulses will be intercepted and it causes to produce a "blind" angle.
3. To avoid formation of a "blind" angle in the "bow" direction, install the scanner closer to the bow than any blinding obstacle.
4. If removal of obstacles on the bow side of the scanner is impracticable, because of the ship's structure, install the scanner more or less off the keel line or elevate the scanner **so** that a dip, or an angle of declination, can be taken between a horizontal line, and the line connecting the antenna and the top of the obstacle.

(1) Method for displacing scanner off keel line.

Displacing the scanner in some distance to the starboard side, displaces the blind spot towards the port side on the scope, which gives a clear view in the bow direction. The displacement can be calculated by the following equations:

$$L_s = 0.4 R + D/2 \text{ (m) } \dots\dots\dots (R < 15 \text{ m})$$

or

$$L_s = 0.025 \sim D/2 \text{ (m) } \dots\dots\dots (R \geq 15 \text{ m})$$

where

$L_s$  = displacement from keel line (m),

$D$  = diameter of an obstacle on keel line (m),

$R$  = distance between scanner and obstacle (m) .

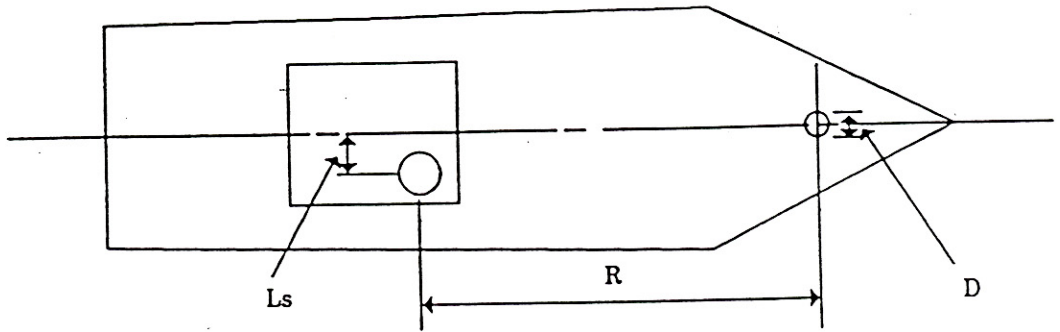

Fig. 5-5 Displacing Scanner Location from Keel Line to Improve Visibility in the Bow Direction

(2) Making dip angle

The location of the scanner unit must be sufficiently elevated so as to make a dip angle (an angle formed by a horizontal line and a line connecting the antenna to the top of the obstacle) of more than  $5^\circ$ , as illustrated.

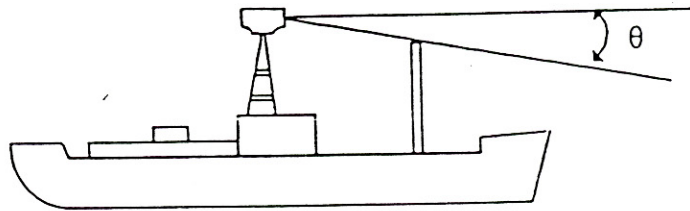

Fig. 5-6 How to Create a Dip Angle

5. Select a location where the scanner is least affected by smoke or hot blast from the stack.
6. Keep the scanner unit as far as possible from the antenna of a direction finder or a VHF transceiver.
7. The scanner distance from the display unit should, preferably, be within the standard length (10 m) of multi-conductor cable. It must never exceed 100 meters.

Note: See the examples on the next page before preparing the mount base for the scanner unit.

### 5.5 Installing Scanner Unit

The scanner unit mount base must be rigid enough to avoid any vibration from engine. The drain tube must not be pinched between the radome and the base.

- (1) Unscrew four bolts and open the upper cover (radome) of the scanner unit.
- (2) Remove the astern-side shield cover of the transceiver unit.
- (3) Remove the cable fixing plate and rubber.
- (4) Feed the inter-connection cable through the cable inlet.
- (5) Fix the rubber and the fixing plate with cable shield terminal.
- (6) Connect 10-pin connector to J1 of MOD PCB and 6-pin connector to J1 of IF PCB.
- (7) Fix the shield cover. (Take care not to pinch the cables between the shield cover and the transceiver unit.)
- (8) Fix the upper cover (radome).

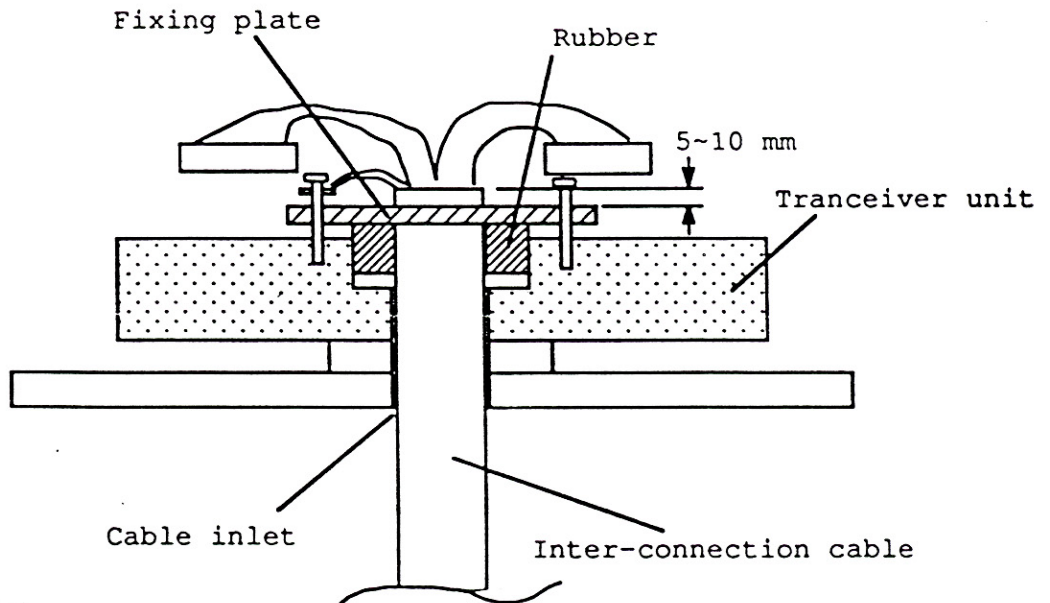

### 5.6 Installing Display Unit

The display unit is designed to be mounted on a desk. Determine the best location by taking the navigational and shipboard operations mentioned below into consideration.

- (1) When the operator raises his head from the radar screen, he must be able to see the bow of the ship.
- (2) Water must not splash on the display unit when a nearby door or window is open.
- (3) The location must be well ventilated and free from severe vibration.
- (4) There must be sufficient service clearance available around the display unit.
- (5) The location must be the minimum safe distance from the magnetic compass to minimize disturbance of the compass. ( 2.0m for master compass, 1.4m for steering compass )

### 5.6.1 Cable Connection

- (1) Connect the scanner cable connector to the back panel of the display unit.
- (2) Connect the power connector to the back panel of the display unit.

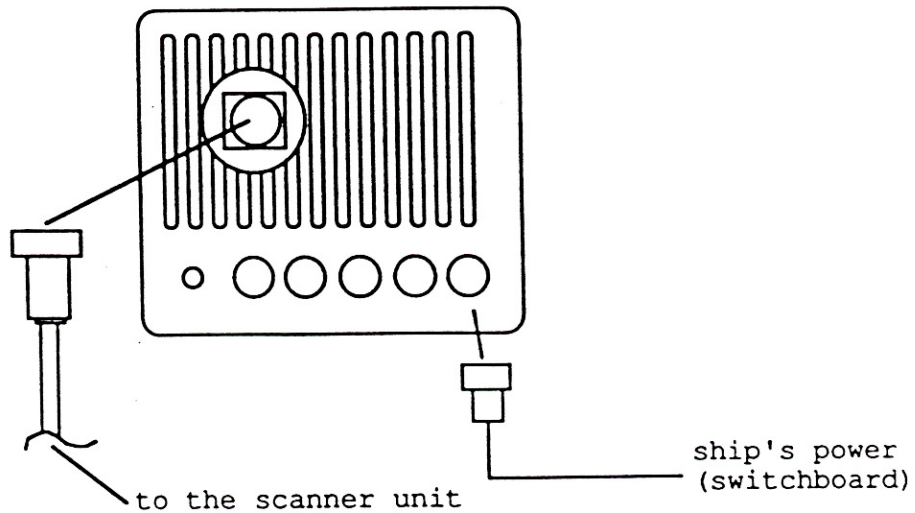

### 5.6.2 Display and Scanner unit grounding

- (1) Ground the display and Scanner unit to prevent high-voltage accidents, and to eliminate unwanted RF radiation.

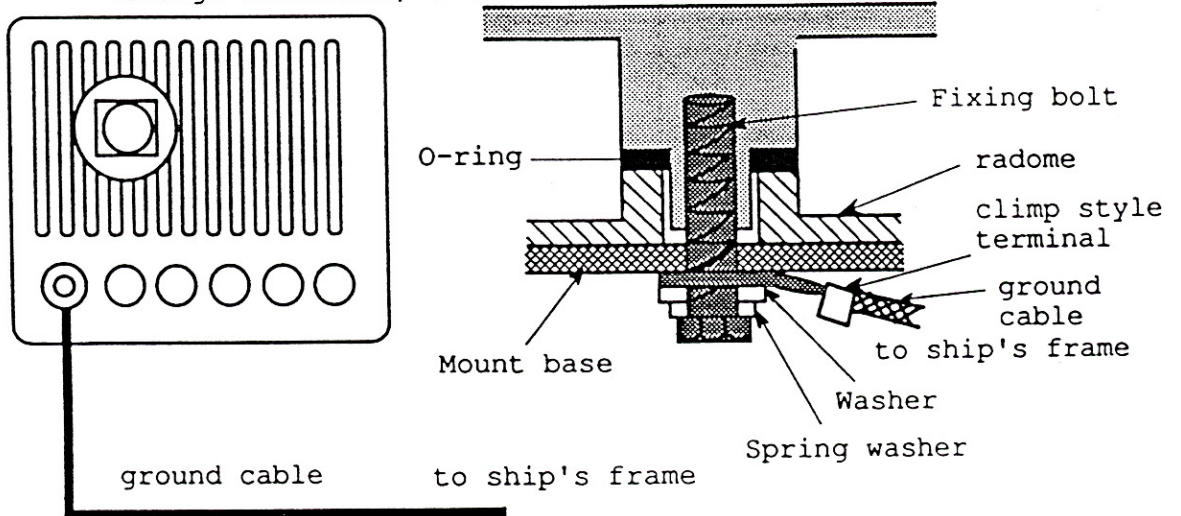

### 5.6.3 Adjustments

After completing installation and connection, turn on power, start the basic operation described in paragraph 2, check for normal operation and then perform the following adjustments or checks.



(1) HEAD DIRECTION ADJUSTMENT

This adjustment is to adjust the radar screen bearing to the real bearing in the SETUP mode.

\* Target catching and measurement

Find a small target in the head direction which is clearly observed on the radar within a range of 0.5 to 1.0 NM.

Measure the target bearing against the ship's head with a compass.

Set the EBL to the bearing measured from the target.

\* Adjustment

Enter the menu by pressing the brilliance key more than 3 seconds.

Select the "(6) HEAD DIRECTION ADJUSTMENT" by pressing the range UP/DOWN-key, and press the brilliance key to enter the underlined menu.

Turn the control knob to set the target on the EBL.

\* Return to the radar screen

Press the brilliance key to return to the menu, or press the OPERATE key to return to the radar screen.

(2) TIMING ADJUSTMENT

This adjustment is to adjust the range on the radar screen to the actual range.

Set the detection range to 0.125 or 0.25 NM and operate the radar, and enter this setup mode to adjust the timing. Then turn the control knob to decrease the diameter of the inner ring of the bright sunspot until its diameter becomes nil and coincides with the sunspot center.

Press the brilliance key to return to the menu, or press the OPERATE key to return to the radar screen.

(3) AUTO TUNE CALIBRATION

This adjustment is to adjust the auto-tuning system to the maximum visibility of the target echoes.

At more than 6 NM range, find several weak but steady echoes.

Enter the menu by pressing the brilliance key more than 3 seconds.

Select the "(4) AUTO TUNE CALIBRATION" by pressing the range UP/DOWN-key, and press the brilliance key to enter to the underlined menu.

(i) Select the mode of "2 CALIBRATION" by the range UP/DOWN key, and turn the control knob to get the maximum picture visibility. In this condition, the tuning system is in manual mode.

(ii) Then select the mode of "1 AUTO" to carry out auto tune system calibration. The calibration will take several minutes.

(iii) When the calibration is finished, the "CALIBRATION COMPLETED" is displayed on the screen. The auto-tuning calibration voltage is displayed at "CONTROL" area.

Press the brilliance key to return to the menu, or press the OPERATE key to return to the radar screen.

## 5.7 Laying Cables

The following should be considered when laying cable.

1. Avoid to use staple or strap to assemble multi-conductor cable and power cable. Keep such cables at least 50 cm from cables connected to other radio equipment.
2. Cable runs between the Scanner and the Display Unit must be as short as practicable.
3. It is recommended that extra cable is left with 60cm loop near the Display Unit for the convenience of installation and maintenance.
4. Exposed cable must closely follow surfaces of the ship's structural members or bulkheads and be secured at about 40 cm intervals by approved saddles as illustrated in Fig. 5-17 (a) and (b).

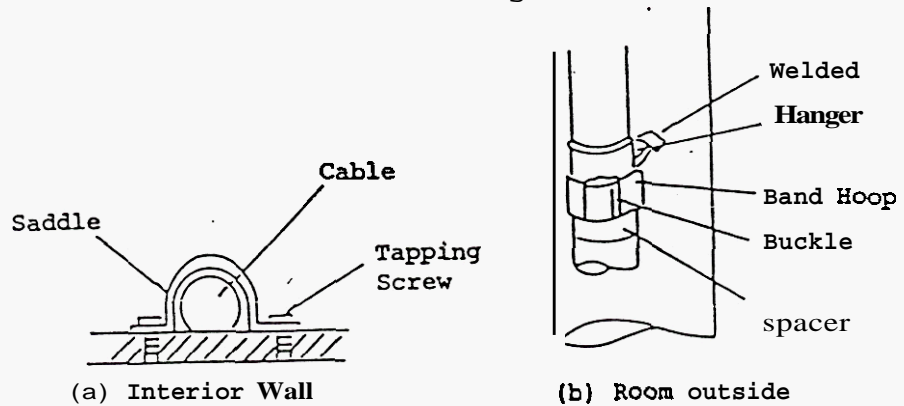

Fig. 5-17 Fastening Cable to Bulkhead or Structural Member

5. When a cable runs through a watertight deck or bulkhead, rigid conduit or pipe of suitable length must be used together with putty to fill the clearance.

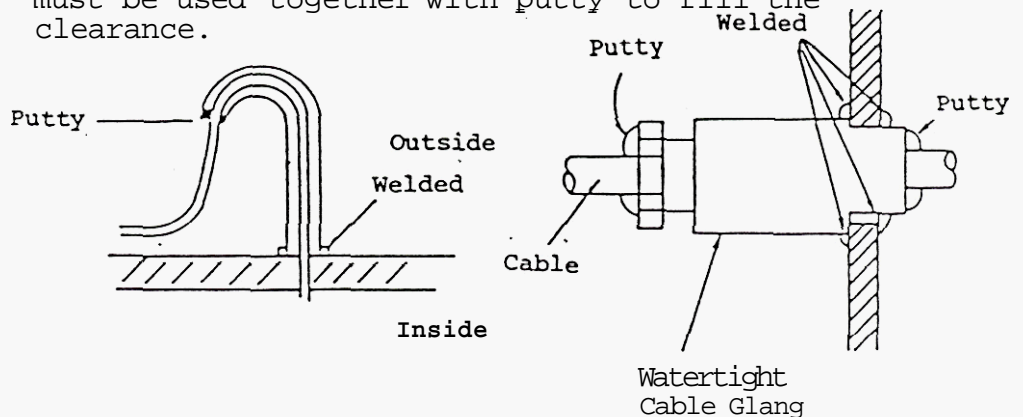
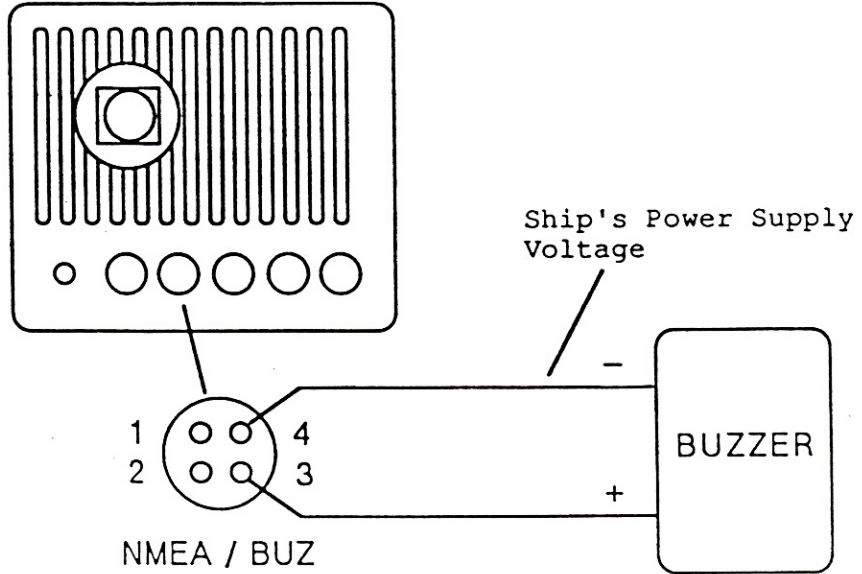

Fig. 5-18 Passing Cable through Watertight Deck or Wall

### 5.8 Installing the External Buzzer

The installation for the external guard zone alarm buzzer is shown below.



Use the buzzer which works with ship's power supply voltage and the current of 1A or less.

## 5.9 Interface

### 5.9.1 Compass Interface

This RF712A radar display unit is equipped with Compass interface as standard. The following signals can be received from compass:

#### 5.9.1.1. Compass Signal

Compass Interface			
Type	(1) Magnet Compass	(2) CETREK555(Magnet Compass)	(3) NZ20A (Gyro Compass I/F)
Signal type	SIN / COS	10-bitserial Data	12-bitserial Data
Signal	SIN, COS, REF	Clock(±), Data(±)	Clock(*). Data(*)
Level	±1V	TTL Level (Photo Coupler Interface)	TTL Level (Photo Coupler Interface)

#### 5.9.1.2. Installation

##### (1) Magnet Compass

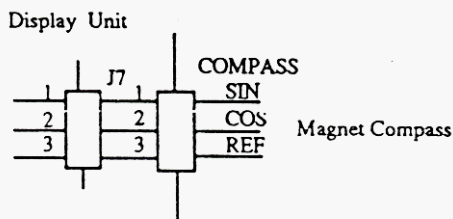

##### (2) CETREK555 (Magnet Compass)

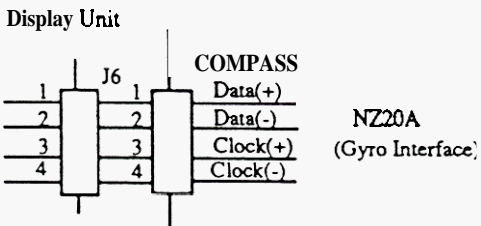
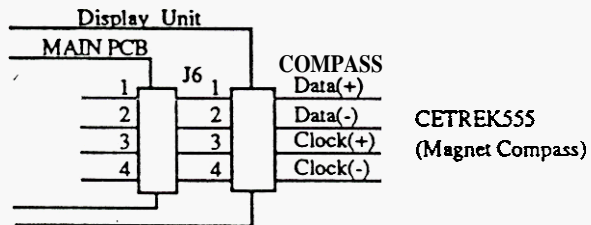

※ In case of (2) or (3), change the connector on the MAIN PCB from J7 to J6.

### 5.9.2 NMEA Interface

This RF712A radar display unit is equipped with NMEA0183 interface for Latitude/Longitude, Waypoint, Speed, Course data from navigation equipments **as** standard. The following format data can be received from LORAN, NNSS, GPS navigator.

#### 5.9.2.1 Navigation Data

Navigation data of NMEA0183 format can be connected to NMEA/BUZ port on the back panel of the display unit. ( underlined data are valid )

- (1) Latitude/Longitude

\$GPGLL,1234.56 N,12345.67,W<CR><LF>

- (2) Speed/Course

\$GPVTG,012.,T,012.,M,12.3,N<CR><LF>

- (3) Waypoint Range/Bearing (true)

\$GPBPI\*,123456,1234.56,N,12345.67,W,012.,T,012.,M,012.3,N,CCCC<CR><LF>

(\* BWR, BWC, BER, BEC available)

- (4) Cross Track Error

\$GPXTE,A,A,1.23,L,N<CR><LF>

#### 5.9.2.2 Magnet Compass Heading Data

Magnet compass data of NMEA0183 format can be connected to COMPASS port on the back panel of the display unit. ( underlined data are valid )

\$XXHDM,123.,M<CR><LF>

#### 5.9.2.3 Installation

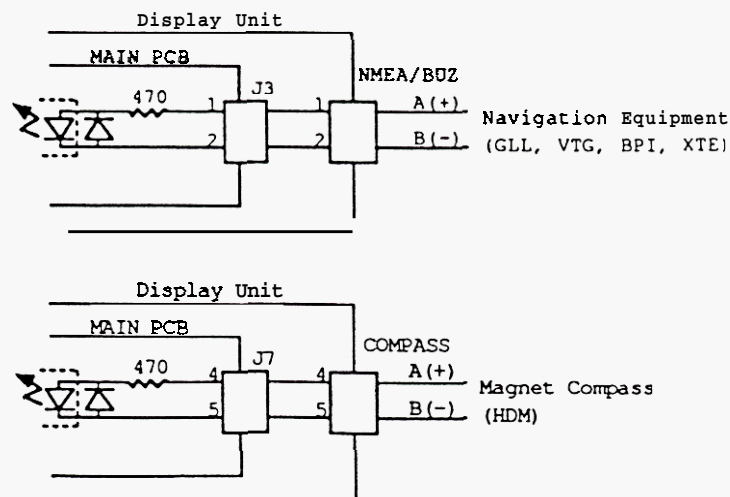

## 5.10 COUNTERMEASUREMENT FOR ELECTROMAGNETIC INTERFERENCE (EMI)

### 5.10 1 On Radar Installation

Anritsu radar provides shields in the units and the inter-unit connection cable. When the radar, however, is closely installed to radio equipment such as Loran receiver, Omega receiver, Transceiver etc., or the radar and/or radio equipment are not sufficiently grounded to the hull or ship's earth, the radar may happen to cause EMI trouble.

Followings are general procedures for reducing EMI due to radars. When installing radars, refer to them, and also check the radio equipment EMI trouble with operating the radar and the radio equipment.

#### (1) Installation Place of Radar

The display unit, scanner unit and inter-unit connection cable should be located apart from the main unit, feeder, antenna coupler and antenna of radio equipment as far as possible.

Especially, proper installation of the feeder, antenna coupler and antenna of radio equipment is very important to improve EMI trouble.

#### (2) Laying Power Supply Cables

Following connections A and B are recommended to reduce conduction noise generated from radar. Connection C should not be used.

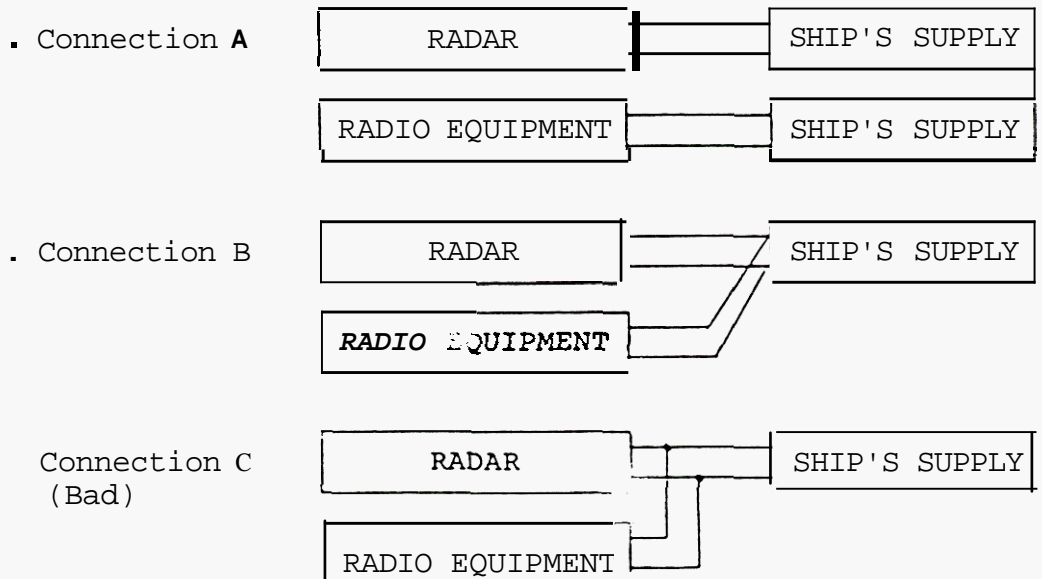

(3) Grounding

All equipment should be firmly grounded at the each nearest hull with copper plates or braided wires.

5.10 2 Radio Equipment and the Using Frequency

Radio Equipment	Using Frequency	Remarks
Loran A Receiver	1850kHz, 1950kHz	Near sea of Japan
Loran C Receiver	100kHz	Global
Omega Receiver	10.2kHz, 11.33kHz, 13.6kHz	Global
Decca Navigator	70kHz to 130kHz	
NNSS	149.88MHz, 399.968MHz	
SSB or DSB Transceiver	1MHz to 150MHz	Depend on the model
Radio Receiver	10kHz to 1GHz	Depend on the model
FAX Receiver	2MHz to 25MHz	

5.10.3 Improvement Procedures for EMI

- (1) Confirm grounding on the radar and radio equipment. However, some equipment, on which grounding is not always necessarily, have a possibility of EMI improving when taking off their grounding. Try to take off grounding.
  - (2) Confirm power supply cable connections and modify to the connection A or B in page 5-10.
  - (3) Try to shift the display unit and inter-unit connection cable of radar to be apart from radio equipment.
  - (4) Try to shift the feeder of radio equipment to be apart from each units and the inter-unit connection cable of radar.
  - (5) Try to shift the antenna coupler and antenna of radio equipment to be apart from the scanner unit and inter-unit connection cable of radar.
- (Note) When carrying out above (3) to (5), check the effect by shifting each units, feeders and/or cables, and decide their best location.

## 6. SPECIFICATIONS

### 6.1 Principal Specification

#### 6.1.1 Overall Characteristics

- (1) Range :  
0.125, 0.25, 0.5, 0.75, 1.5, 3, 6, 12, 24, 36 NM
- (2) Range discrimination:  
Better than 20 meters
- (3) Minimum detection range:  
Better than 20 meters
- (4) Bearing accuracy:  
Within +/- 1 degree
- (5) Bearing discrimination:  
Better than 3.9 degree
- (6) Range accuracy:  
Within +/-0.8% of setting range, or +/-8 meters,  
whichever greater
- (7) Environmental conditions:  
Temperature of -25°C to +55°C for scanner unit  
and -15°C to +55°C for display unit  
Relative humidity below 95% at 35 c
- (8) Power Supply:  
Internal power voltages:  
10.2 to 41.6 Vdc  
Power consumption: Less than 65 W  
Separate power supply (options):  
100/110/220 Vac +/-10%, 50/60 Hz, single phase

#### 6.1.2 Scanner Unit

- (1) Antenna Type  
Center-fed slotted array
- (2) Number of revolutions:  
approximately 24 rpm
- (3) Polarization  
Horizontal
- (4) Antenna directivity  
Horizontal Beam Width 3.9 degree  
Vertical Beam Width 25 degree
- (5) Wave type and frequency:  
PON, 9410 MHz +/-30 MHz
- (6) Peak Power Output  
Within 4 kW +/-50%
- (7) Pulse width and pulse repetition frequency  
0.08 μs; 1800 Hz  
0.25 μs; 1200 Hz  
0.8 μs ; 600 Hz
- (8) Duplexer (TR switch):  
Circulator
- (9) Reception system:  
Superheterodyne with low noise front-end module
- (10) IF Frequency:  
60 MHz (LOG IF AMP.)
- (11) IF Bandwidth:  
15 MHz (for 0.08/0.25 μs transmitting pulse width)  
5 MHz (for 0.8 μs transmitting pulse width)
- (12) Local oscillation frequency:  
Transmitting frequency + 60 MHz



- (13) Receiver Tuning:  
Indicated by bar-graph marks on CRT by microcomputer control
- (14) Inter-connection Cable:  
9CD-3349 (10 m)

### 6.1.3 Display Unit

- (1) Display system:  
PPI presentation on raster-scan base
- (2) CRT: 10-inch rectangular monochrome CRT
- (3) Range scale and range rings:

Range Scale(NM)	0.125	0.25	0.5	0.75	1.5	3	6	12	24	36
Ring Interval(NM)	0.0625	0.125	0.25	0.25	0.25	0.5	1	2	4	6
Number of Rings	2	2	2	3	6	6	6	6	6	6

- (4) Variable Range Markers (VRM) :  
Numerical Display: Four digits  
Accuracy: Within +/-1.5% of setting range, or +/-50 meters, whichever greater  
Unit: NM / KM / SM (selectable)  
VRM2: VRM2 is selectable at SET UP mode.
- (5) Electronic Bearing Lines (EBL) :  
Steps: 0.2 degree steps  
EBL2: EBL2 is selectable at SET UP mode.
- (6) Display Modes:  
Heading Up: nu  
Following display modes are selectable at SET UP mode.  
Head Set: HS  
North Up: NU (\*)  
Course Up: CU (\*)  
(The \* mark modes are available only when compass is connected.)
- (7) Display brightness of echoes: Four levels
- (8) Off-centering:  
60% forward or 60% backward of the setting range
- (9) Guard Zone:  
Setting range: 0.5 NM or more  
Setting bearing: Approx.6 degree steps  
Setting area: Selectable from four patterns  
Zone width: 0.4 NM (fixed)
- (10) Interference Rejector (IR): Built-in

### 6.1.4 Interface Signals

- (1) Output radar signals for Radar Monitor.
  - (a) Video signal: Negative polarity  
Raw signal from LOG IF amplifier  
Max.3 Vp-p, Zo= 50 ohm
  - (b) Radar trigger: Positive polarity  
10 Vp-p, 1.2 μs pulse width  
Zo= 50 ohm
  - (c) Bearing Signal: TTL level pulse  
1080 (200, 360, or 2048) pulses/rev. position

- 30 to 70% duty
- (d) SHF signal: TTL level pulse  
use Negative edge
  - (2) Compass Interface:
    - (a) Magnet Compass: SIN/COS signal (+/- 1 Vdc)
    - (b) Gyro Interface(option)
  - (3) External buzzer for Guard Zone:  
ON/OFF controlled ship's power supply for external buzzer
  - (4) NMEA-0183  
GLL, XTE, VTG, HDM, BWC... formats

6.1.5 Allowable Safe Distance from Magnetic Compass

- For master compass:  
 Display Unit -- 2.0 m  
 Scanner Unit -- 2.0 m
- For steering compass:  
 Display Unit -- 1.4 m  
 Scanner Unit -- 1.4 m

6.2 Standard Equipment

The RA770UA is composed of the units, accessories, and spare parts listed in the following table.

Table 6-1 Component List

No.	Name	Type	Q'ty	Remarks
1	Scanner Unit	RB709A	1	
2	Display Unit	RF712A	1	
3	Accessories			
3.1	Inter-connection Cable	9CD-3349	10 m	
3.2	Power Supply Cable		2 m	
3.3	Pedestal		1	
3.4	Hood		1	
3.5	Bolt		1 set	for mounting scanner
3.6	Instruction Manuals		1	
4	Spare Parts			
4.1	Fuse		1 set	

6.3 Option

- (1) AC Power Supply RP113A Input Voltage 100/110/220 Vac
- (2) AC Power Supply 69-1E-A Input Voltage 100-125  
/ZOO-250 Vac
- (3) NMEA Cable 245138091 with connector (5 m)

A

B

C

D

E

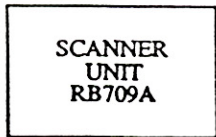

※ INTER-CONNECTION CABLE  
9CD-3349 (10m standard)

RADAR MONITOR CABLE  
(shielded 20m max.)

NAVIGATION  
EQUIPMENT



RADAR MONITOR  
RF704A / RF706A  
RF707A / RF708A

DC POWER  
SUPPLY  
12/ 24/ 32V

※ POWER SUPPLY CABLE  
(2m)

RECTIFIER

Cable  
250V-DPYC-1.25

DC POWER  
SUPPLY  
12/ 24/ 32V

AC POWER SUPPLY  
100, 110, 220V

Note 1. ※ 印のケーブルはアンリツ支給  
※ : To be supplied by ANRITSU

2. 点線はオプション  
-----: Option

7.5/52

QTY	ITEM	PART No.	DESCRIPTION	MATERIAL	FINISH	NOTE

CHECKED BY <i>H. Onda</i> 10 Sept '91	TRACED BY	SCALE
APPROVED BY <i>T. Hidai</i>	DRAWN BY <i>T. Inudou</i> July. 30 '91	:

DEP	TITLE RA770UA 総合系統図 GENERAL SYSTEM DIAGRAM	DRAWING No. 24W137212 /
-----	--	----------------------------



A  
B  
C  
D  
E

96/52

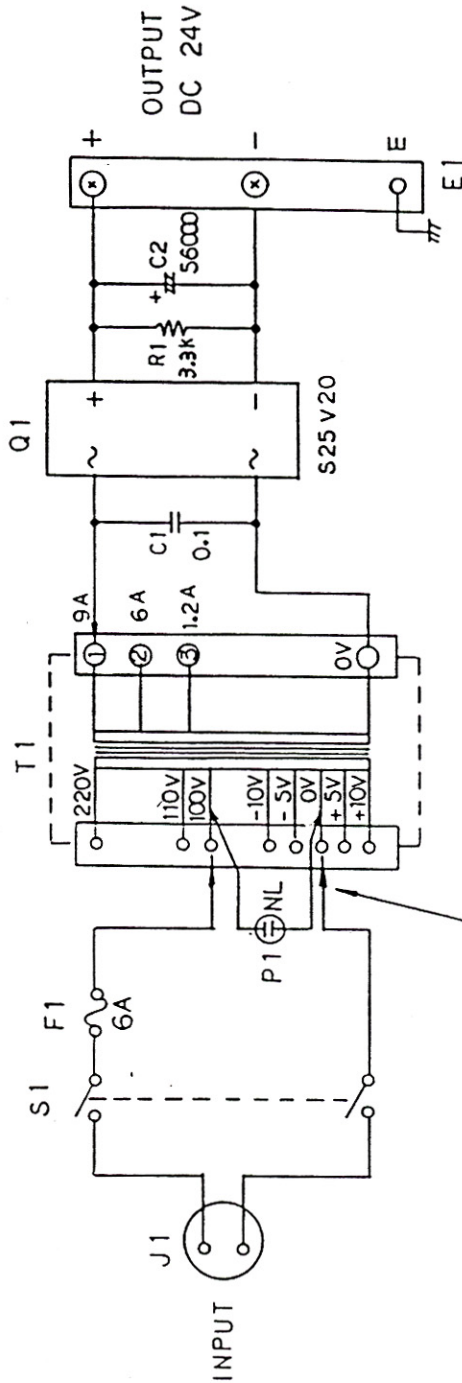

入力電圧によりタップ・変更  
Selection of input voltage

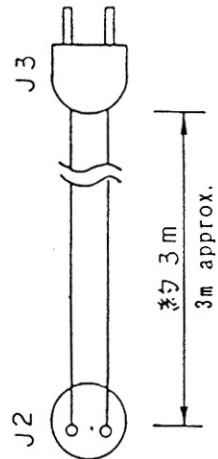

QTY	ITEM	PART No.	DESCRIPTION	MATERIAL	FINISH	NOTE
	CHECKED BY	TRACED BY		SCALE		
	APPROVED BY	DRAWN BY				
DEP	TITLE		DRAWING No.			
	RP113A 交流電源 回路図		RECTIFIER UNIT CIRCUIT DIAGRAM RP113A		24W130456 /	

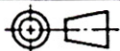

A  
B  
C  
D  
E

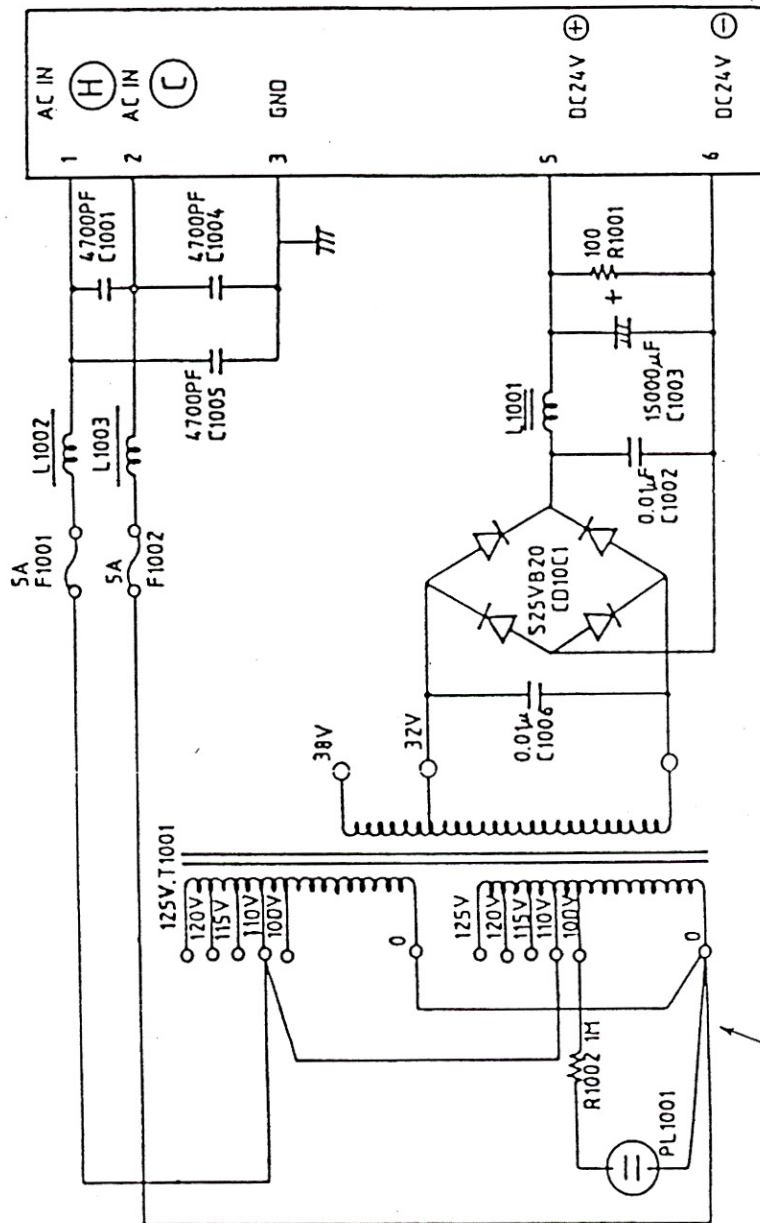

入力電圧によりタップ変更  
Selection of input voltage

QTY	ITEM	PART No.	DESCRIPTION	MATERIAL	FINISH	NOTE
-----	------	----------	-------------	----------	--------	------

CHECKED BY *12 Jan '92 H. Suda* TRACED BY  
 APPROVED BY *T. Hidai* DRAWN BY *13 Jan '92 J. Inudou*

SCALE  
 :

DEP	TITLE	DRAWING No.
	69-1E-A 整流器回路図 RECTIFIER UNIT CIRCUIT DIAGRAM	24W138330

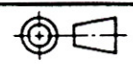

23W61202 1/1

APPLICATION

REVISIONS

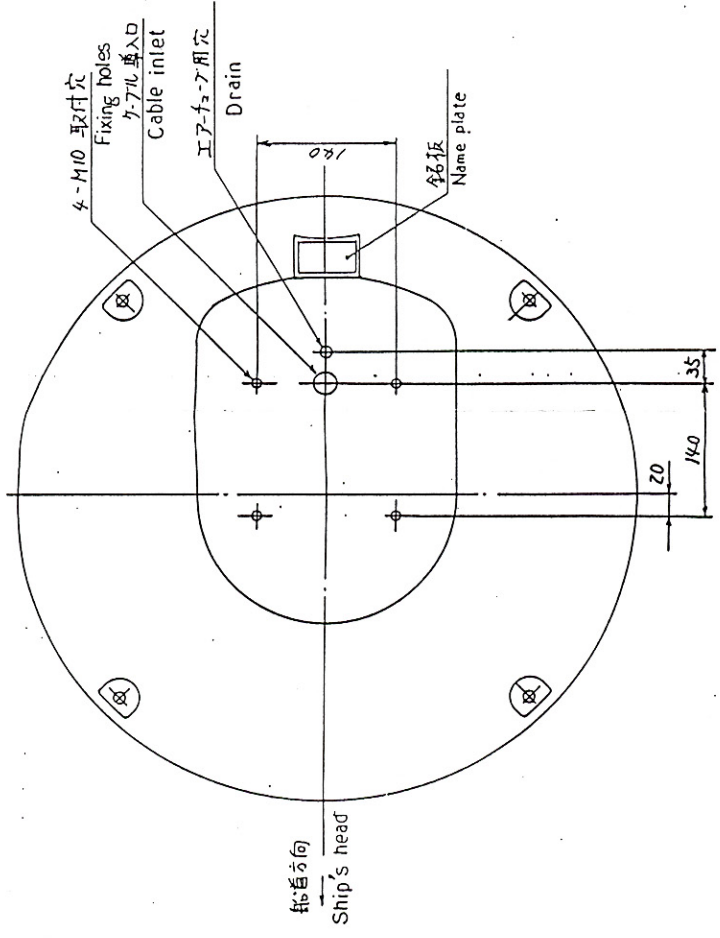
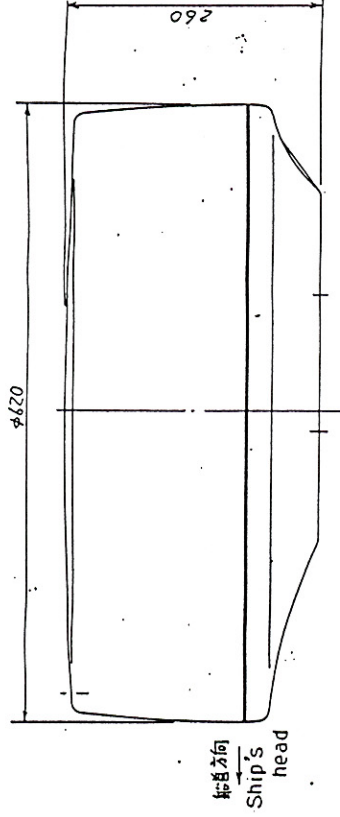

取付面より見3.  
Bottom view

Weight : 9.5kg Approx.  
重量 : 約9.5kg  
Unit : mm  
単位 : mm

QTY	ITEM	PART No.	DESCRIPTION	MATERIAL	FINISH	NOTE
	CHECKED BY	<i>T. Iwada</i>	TRACED BY	<i>A. Aono</i>	SCALE	
	APPROVED BY	<i>T. Hidai</i>	DRAWN BY	<i>H. Hidai</i>		
TITLE RB709A スキャナユニット外觀図 Scanner unit external view						
DRAWING No. 23W61202 1/1						

DEP.



23 W56729

APPLICATION

REVISIONS

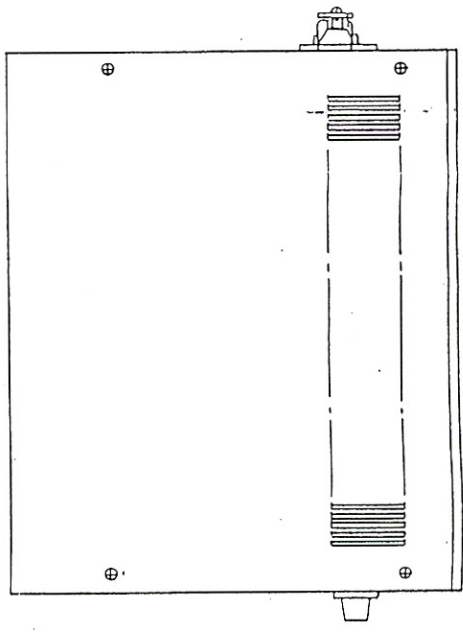
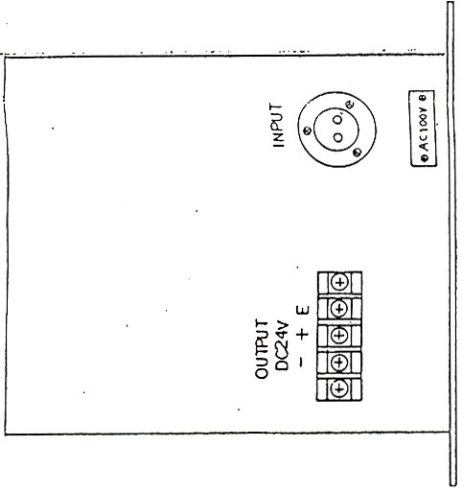
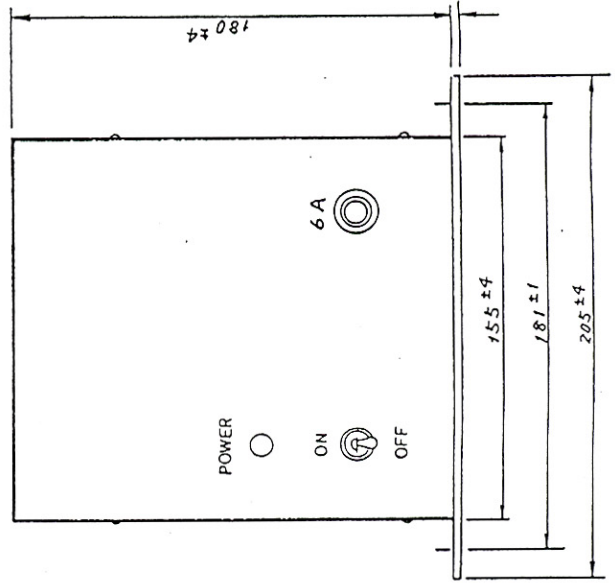
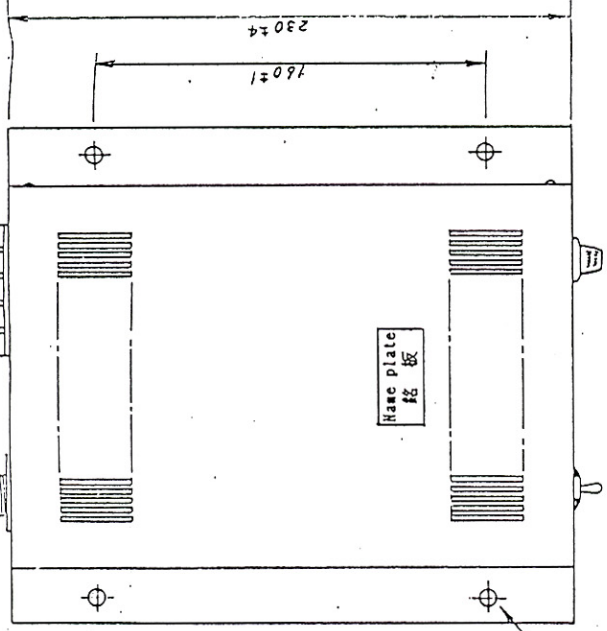

Weight : 11kg Approx.  
重量 : 約11kg  
Unit : mm  
單位 : mm

QTY/ITEM	PART No.	DESCRIPTION	MATERIAL	FINISH	NOTE
CHECKED BY 13 Jan. 92 B. B. de		TRACED BY	SCALE		
APPROVED BY T. Hidai		DRAWN BY 13 Jan. 92 S. I. Iwada			
TITLE R P113A		OUTLINE DRAWING			
交流電源		RECTIFIER UNIT			
外觀図		R P113A			

DEP

DRAWING No.

23W56729



23W61200 1/1

APPLICATION

REVISIONS

2 3 4 6 7 8

A

B

C

D

E

DEP

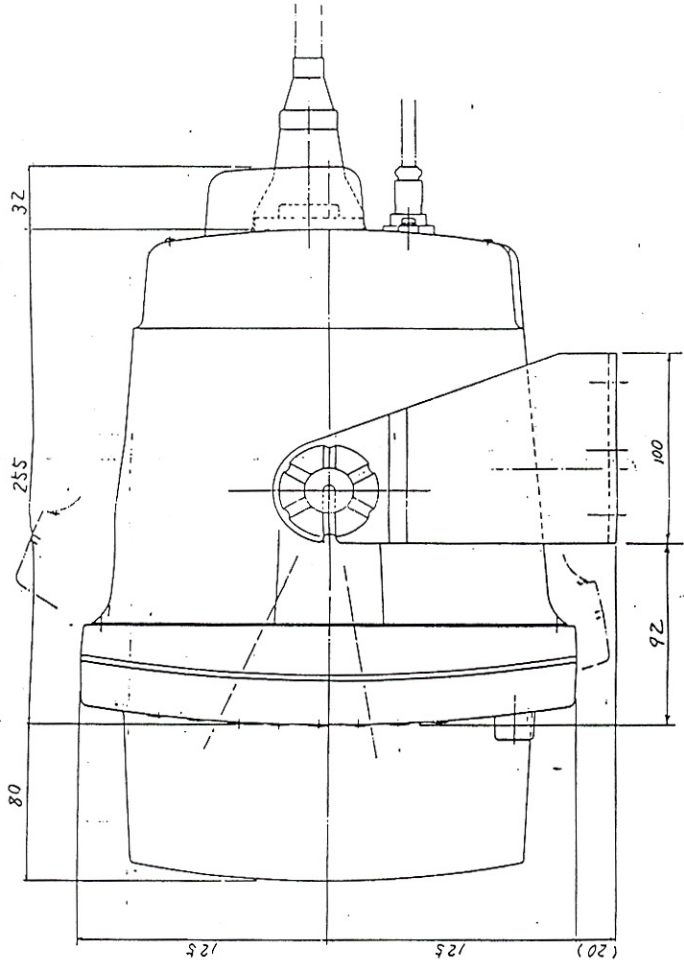
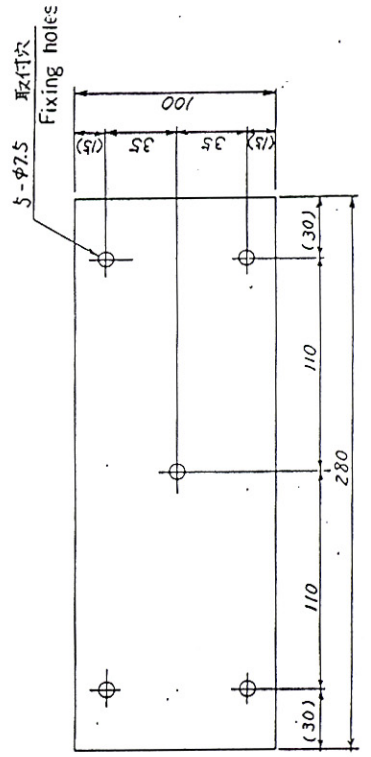
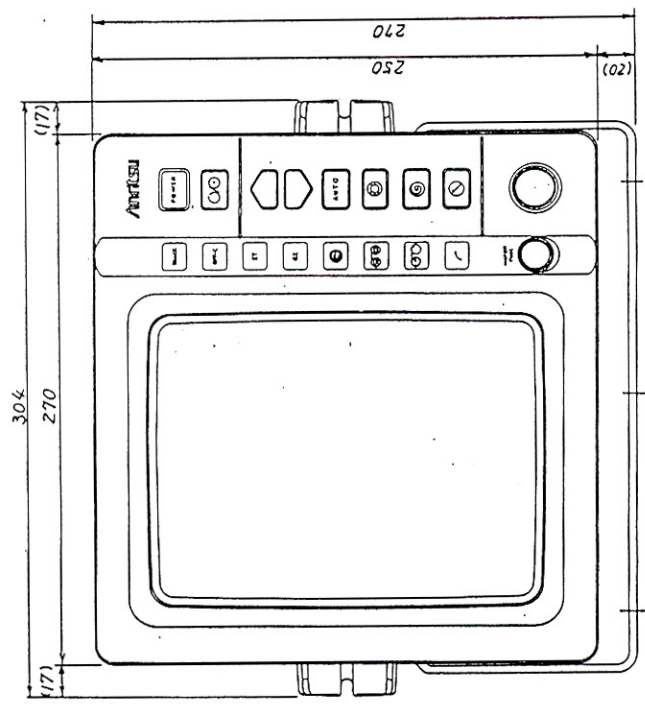
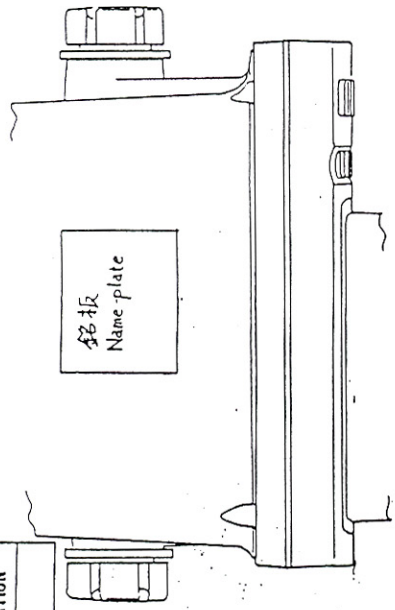

Weight : 6.5kg Approx.  
重量 : 約6.5kg

Unit : mm  
単位 : mm

QTY	ITEM	PART No.	DESCRIPTION	MATERIAL	FINISH	NOTE
	CHECKED BY	<i>T. Souden</i>	TRACED BY <i>T. Aizawa</i>			
	APPROVED BY	<i>T. Hidaka</i>	SCALE			
TITLE RF712A デイスプレイユニット外觀図 23W61200 1/1						
DRAWING No. Display unit external view						

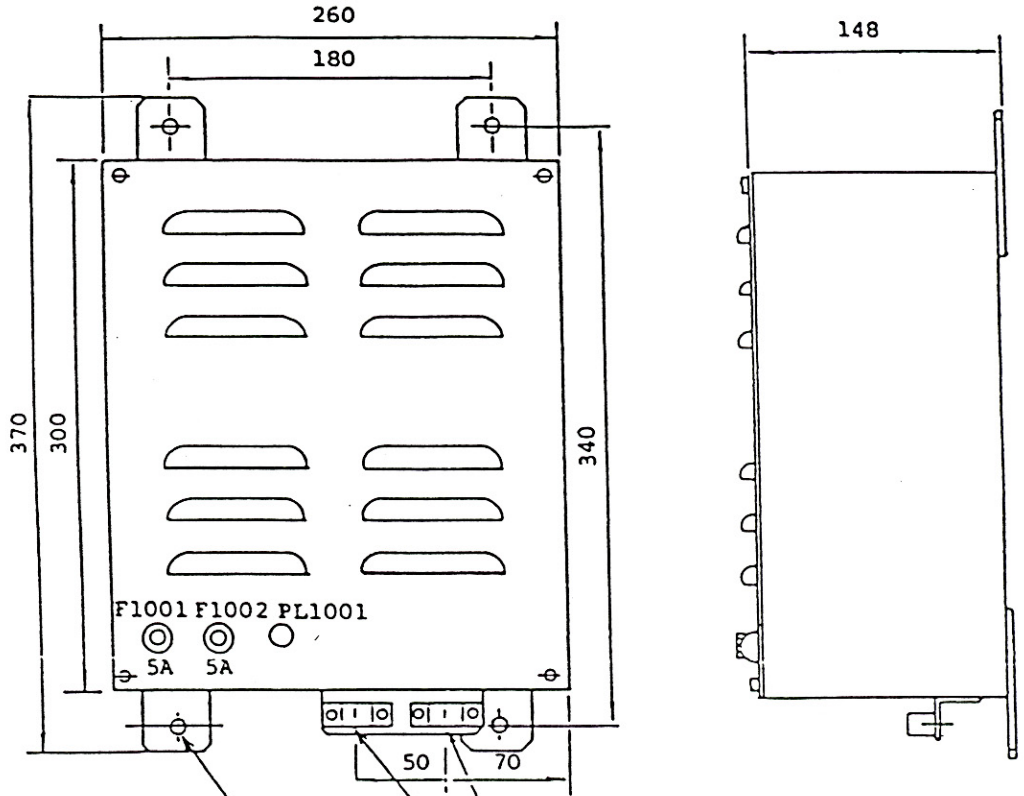

UNIT mm  
 単位 mm

CABLE CLAMPER  
 ケーブルクランパ

4- $\phi$ 10 FIXING HOLE

取付穴

WEIGHT 15kg APPROX

重量 15kg

69-1E-A  
 RECTIFIER UNIT EXTERNAL VIEW  
 整流器外觀図

APPLICATION

REVISIONS

A

B

C

D

E

9CD-3349 ケーブル

MOD PCB J1	CORE CONDUCTOR COLOR	FUNCTION
1	50/0.18 BROWN	MOTOR(+)
2	50/0.18 VIOLET	MOTOR(-)
3	12/0.18 BLACK	GND
4	12/0.18 RED	+12 V
5	12/0.18 GREEN	AZLP
6	12/0.18 GRAY	P.S
7	SHIELD BROWN	TRIG.
8	SHIELD BRAID	GND
9		NC
10	12/0.18 PINK	+300 V
IF PCB J1	CORE CONDUCTOR COLOR	FUNCTION
1	CX GRAY	VIDEO
2	CX BRAID	GND
3	12/0.18 ORANGE	TUNE.O
4	12/0.18 VIOLET	TUNE.M
5	12/0.18 BLUE	TUNE.R
6	12/0.18 WHITE	SHF

SCANNER UNIT

9CD-3349 ケーブル			
CORE CONDUCTOR COLOR	FUNCTION	J1	
CX GRAY	VIDEO	1	
CX BRAID	GND	2	
SHIELD BROWN	TRIG.	3	
SHIELD BRAID	GND	4	
12/0.18 ORANGE	TUNE.O	5	
12/0.18 VIOLET	TUNE.M	6	
12/0.18 BLUE	TUNE.R	7	
12/0.18 GRAY	P.S	8	
12/0.18 WHITE	SHF	9	
12/0.18 GREEN	AZLP	10	
	NC	11	
12/0.18 PINK	+300 V	12	
12/0.18 RED	+12 V	13	
12/0.18 BLACK	GND	14	
50/0.18 BROWN	MOTOR(+)	15	
50/0.18 VIOLET	MOTOR(-)	16	

DISPLAY UNIT

94/52

QTY	ITEM	PART No.	DESCRIPTION	MATERIAL	FINISH	NOTE
CHECKED BY		10 Sept '91 H. Jida		TRACED BY		SCALE
APPROVED BY		T. Hidai		DRAWN BY		July 30 '91 J. Inudou
DEP	TITLE			DRAWING No.		
	RA770UA 相互結線図 INTER-CONNECTION DIAGRAM			24W137213		



24W137121 /

APPLICATION

229UZ7539

REVISIONS

A

B

C

D

E

45/52

To DISPLAY

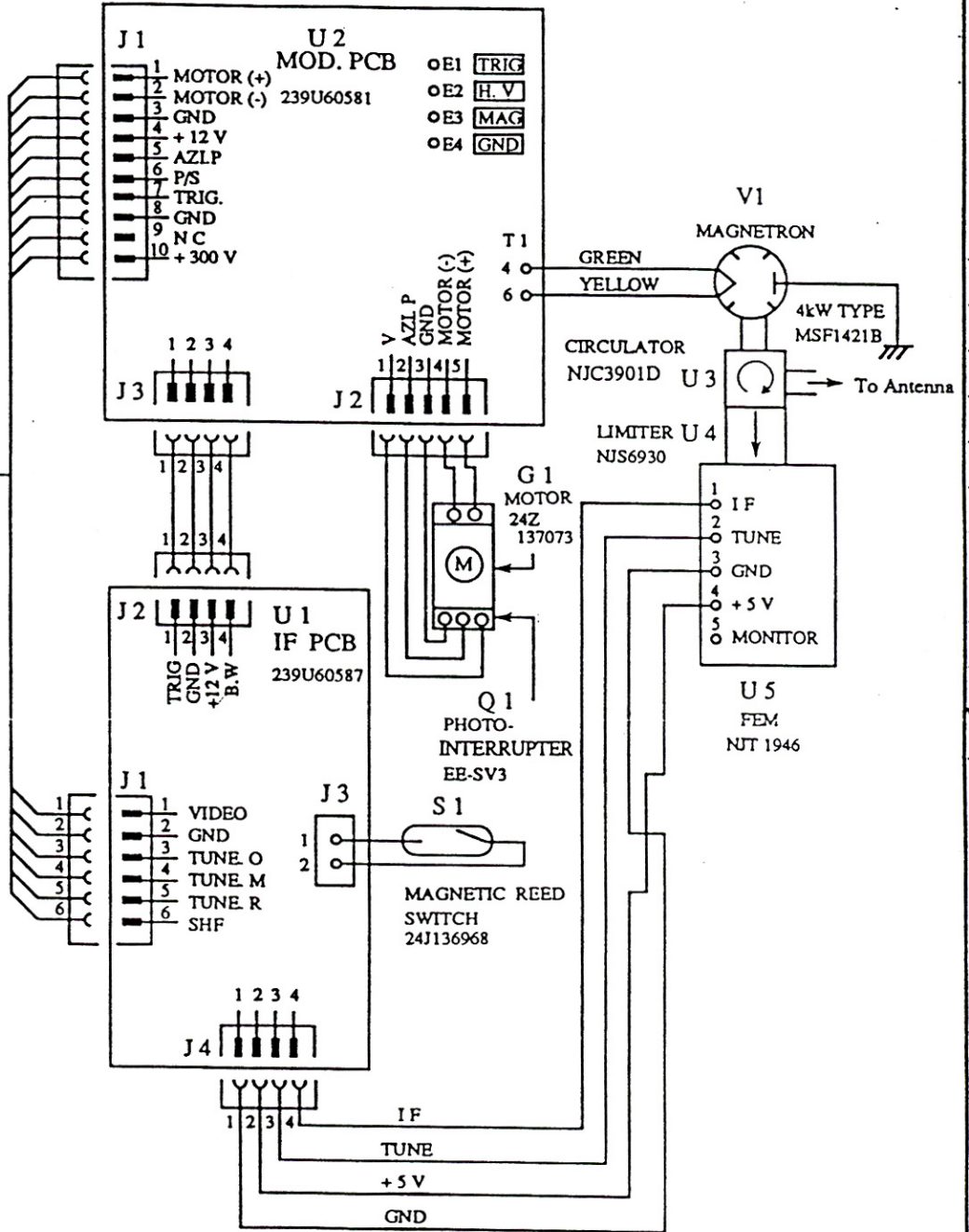

QTY	ITEM	PART No.	DESCRIPTION	MATERIAL	FINISH	NOTE
CHECKED BY		10 Sept. '91 H. Onda		TRACED BY		SCALE
APPROVED BY		T. Hidai		DRAWN BY		July 30 '91 T. Inoue
TITLE				DRAWING No.		
スキヤナユニット回路図 SCANNER UNIT CIRCUIT DIAGRAM				24W137121 /		